

**A Rationale and Guideline to
Recommended Practice SAE J2249**

**Wheelchair Tiedowns and Occupant Restraint
Systems for Use in Motor Vehicles**

Technical Report No. 8

RERC on Wheeled Mobility

University of Pittsburgh

**Lawrence W. Schneider Ph.D.¹, Douglas A. Hobson, Ph.D.²
and
Gina E. Bertocci, Ph.D.².**

June 1999

¹ Research Scientist, University of Michigan Transportation Research Institute, University of Michigan

² RERC on Wheelchair Mobility, Department of Rehabilitation Science, University of Pittsburgh

Contents

I. Introduction	4
II. Harmonization with Other Standards.....	7
III. Basic Principles of Occupant Protection.....	9
IV. SAE J2249: Wheelchair Tiedown and Occupant Restraint Systems.....	14
V. Guidelines for Users of WTORS.....	46
VI. Guidelines for WTORS Transportation Authorities and Installers	51
VII. Guidelines for WTORS Designers.....	56
VIII. Future additions to RP J2249	60
IX. Appendices.....	61
A) Reference Standards, Laws and Regulations	
B) Glossary of Terms	
C) List of Participant Organizations, Companies and Individuals	

Acknowledgments

Primary funding for this guideline document was provided to the University of Pittsburgh, Rehabilitation Engineering Research Center on Wheelchair Technology by the National Institute on Disability and Rehabilitation Research, US Department of Education, Washington, DC (grant #H133E30005). Opinions expressed in this document are those of the authors and should not be construed to represent the opinions of NIDRR.

Over a 10 year period many organizations, commercial firms and individuals contributed to the development and completion of RP J2249. This effort, and in turn this guideline, has only been possible as a result on these many and most significant contributions. Appendix C is a an attempt to recognize the majority of those who have contributed, but undoubtedly will fail to acknowledge all--and for that we apologize.

A Rationale and Guideline to Recommended Practice SAE J2249 Wheelchair Tiedown and Occupant Restraint Systems for Use in Motor Vehicles

I. Introduction

We live in a mobile society where access to, and use of, public and private motor vehicle transportation is essential to daily living. We are also in a time when public concern and desire for vehicle crash worthiness and occupant safety is at an all-time high, due largely to government regulation and implementation of airbags, seat-belt laws, and an increase in public education through the media and other materials on the need for effective occupant restraints .

We also live in a time when the number of people with physical disabilities who require the use of a wheelchair for movement and daily functioning is at a new high and increasing. These are people for whom motor-vehicle transportation is also essential. Over the past two decades, federal legislation has been passed and implemented³ to assure that people in wheelchairs are not excluded from public transportation. After-market equipment has been developed to adapt or modify vehicles so that people in wheelchairs can get in and out of, and, in some cases, operate a motor vehicle. While many wheelchair users are able to transfer to the vehicle seat and store the wheelchair during transit, many are not. For the latter group, the legislation that has assured access to motor vehicles for people in wheelchairs, has generally not been followed by legislation that assures a safe ride⁴. Thus, persons seated in wheelchairs while traveling in motor vehicles, including children traveling to school, adults traveling in public transit and paratransit vehicles, elderly traveling to and from nursing homes, and wheelchair-seated drivers and passengers of personally licensed vehicles (usually vans), have generally traveled at significantly higher risk of injury in a vehicle crash than the able-bodied population. This increased risk is not so much a result of a reduced tolerance to injury for this population of people (which may also be the case) as it is due to the absence of suitable seating and effective and appropriate occupant restraint systems, comparable to that available to travelers in vehicle seats that are regulated by federal safety standards.

³ IDEA and ADA

⁴ It should be noted that during the development of SAE J2249, FMVSS 222 for *School Bus Passenger Seating and Crash Protection* was upgraded to include static strength requirements for OEM wheelchair tiedowns and occupant restraints, as well as installation for forward-facing wheelchairs.

Background

SAE Recommended Practice J2249 *Wheelchair Tiedowns and Occupant Restraints for Use in Motor Vehicles* (hereafter referred to as J2249) was developed *over a ten year period* by the Restraint Systems Task Group of the SAE's Adaptive Devices Subcommittee (ADSC) in recognition of the need to improve after-market equipment used to secure wheelchairs and restrain wheelchair occupants during motor-vehicle transportation. While a primary element of this recommended practice is a dynamic strength test of wheelchair tiedown and occupant restraint equipment conducted on an impact sled in a manner similar to FMVSS 213 for child restraint systems (CRS), the practice includes many other requirements related to basic principles of occupant protection, as well as basic principles of good engineering and design practice.

SAE RP J2249, *Wheelchair Tiedowns and Occupant Restraints for Use in Motor Vehicles*, was first published in October 1996. The goal of this companion document is to provide guidance in the use of J2249, and to provide interpretation, explanation, and rationale for its various provisions and parts. This guideline document is written primarily for manufacturers of Wheelchair Tiedown and Occupant Restraint Systems (WTORS), but will also be useful to consumers and third-party groups who purchase, use, or install WTORS. It provides insight into the requirements set forth in the Recommended Practice, gives the rationale behind the requirements, and clarifies the intentions and limitations of the of the requirements. It also references parallel efforts that have taken place in other countries and indicates where attempts at harmonization have been successful.

Overview and Purpose - i.e., what the recommended practice is and what it isn't.

As stated in the Foreword to the Recommended Practice, the purpose of SAE J2249 is to establish requirements for wheelchair tiedowns and occupant restraint systems (WTORS) sold as after-market equipment for installation and use in motor vehicles. WTORS are not covered by OEM regulatory provisions of safety standards established by the National Highway Traffic Safety Administration (NHTSA) through Federal Motor Vehicle Safety Standards (FMVSS), and likely never will be. For example, seats in motor vehicles must comply with the provisions of FMVSS 210, occupant restraints must comply with FMVSS 209, and the combination of seats and occupant restraints must comply with FMVSS 208, a full-vehicle dynamic impact test. Also, school buses and their interior components, including seats, must comply with FMVSS 222 and child restraint systems (CRSs) must comply with FMVSS 213, a dynamic or sled impact test.

In setting forth the requirements of SAE J2249, it was recognized by the Task Group that human tolerance to injury resulting from impact forces generated under vehicle crash conditions varies widely across the population and that elderly and disabled individuals may be at higher risk

(i.e., have lower injury tolerance) to injury than younger and stronger *non-disabled* individuals. It is important, however, to understand that the goal of the Task Group and J2249 was not to achieve a comparable level of injury risk for people in wheelchairs, but rather to provide them with the opportunity to use occupant restraints that have a comparable level of performance to restraints provided by the vehicle manufacturer that must conform to federal motor vehicle safety standards (FMVSSs).

SAE recommended practices, such as J2249, are not mandatory standards in the same sense as federal motor vehicle standards. However, in the absence of federal standards for after-market vehicle equipment like wheelchair tiedowns, an SAE recommended practice can serve the purpose of a national standard if consumers, third-party payers, state agencies, and transportation groups insist on purchasing, installing, and using equipment that conforms with the recommended practice.

II. Harmonization with Other Standards

Harmonization of manufacturing standards across national and international borders is immensely important to both industry and consumers who wish to freely provide and access products from other countries. In Europe, the European Common Market (EC) uses the CEN standards to enforce harmonization. The International Standards Organization (ISO) operates on a world-wide scope and accepts participants from any country that wishes to be a participating or observing member. CEN, in general, accepts ISO standards as the foundation for any EC standards. In North America, there is not an official mechanism to facilitate harmonization between countries. Therefore active participation in ISO by North American industry is the most logical vehicle to facilitate harmonization of standards between countries and access to world-wide markets.

Regarding wheelchair transportation safety, standards development must be based on the recognition that wheelchair occupant safety is a systems problem. That is the scope of the solution, and therefore the standards, most ultimately include the wheelchair, the wheelchair securement device, the occupant restraint, and the vehicle. In addition to the work in the USA on RP-SAE J2249, parallel efforts have taken place in Canada (Z605) and are currently underway in the International Standards Organization (ISO) in documents 10542, parts 1-5. In Australia, a standard for wheelchair tiedowns and occupant restraints has been in existence in Australia since 1987 (AS-2942). The initial version of the Australian standard served as a launching point for the SAE standard, which then provided input to both the Canadian and ISO versions of this standard. Although AS-2942 was updated in 1994, it continues to use significantly different impact test methods to those in SAE J2249, CSA Z605, and ISO 10542.

Similarly, parallel efforts have been initiated on wheelchairs and transport vehicles. ANSI/RESNA WC/19, *Wheelchairs for Use in Motor Vehicles*, specifies design and performance requirements for wheelchairs designed for occupancy in a motor vehicle when secured by a four-point strap-type tiedown in a forward-facing orientation. It is scheduled for implementation in mid 1999. In Canada, the comparable standard, Z604, was completed in February, 1996 but is now being upgraded for improved compatibility with ANSI/RESNA WC/19. Similarly, ISO 7176/19, *Wheelchairs - Wheeled Mobility Devices for Use in Motor Vehicles*, is scheduled for completion in the spring of 2000. Diligent efforts to achieve harmonization with these other efforts have been made by the U.S. teams. Although differences remain, harmonization has been achieved for the critical dynamic test requirements in each case, in that, like the standards for wheelchair tiedowns and occupant restraints systems, all standards require wheelchairs to be tested under 48-kph, 20-G impact condition.

For vehicles, a parallel effort has taken place but unfortunately harmonization has not occurred as the timing of development and the

people involved are largely different. In the USA, in addition to federal motor vehicle safety standards (FMVSSs), which govern the safety requirements for all OEM motor vehicles, including school buses, the American with Disabilities Act (ADA) specifies requirements for wheelchair access, on-board wheelchair station space, and wheelchair securement and occupant restraint for public transit vehicles. For modified private vehicles, such as personally-licensed vans, other SAE Task Groups within the ADSC are actively developing recommended practices for vehicle modifications, including hand controls, ramps and lifts, and structural modifications. In Canada, D-409 governs the safety design of small transport vehicles, such as school buses and paratransit vehicles. In ISO, TC-XXX, WG-4 is developing a similar standard for small transit vehicles. In general, however, and unfortunately, there is little harmonization between the requirements of these vehicle standards, and the requirements for WTORS as specified in SAE J2249, CSA Z605, and ISO 10542.

Appendix A of this document contains a listing of these interrelated standards and their current development status. Since all of the documents are reviewed and revised approximately every five year, it is important to obtain the most current version before attempting to conform to any of contained requirements. As each of these standards is updated, it is also hoped that improvements in harmonization between them will be achieved.

III. Basic Principles of Occupant Protection

As indicated above, much of SAE J2249 is based on ensuring that the design of the WTORS adheres to some basic principles of occupant protection. For the most part, these principles are based on the simple fact that most serious injuries in a vehicle crash are due to:

- the occupant moving into and contacting interior vehicle structures,
- the occupant being ejected and contacting structures outside of the vehicle, or to
- the high restraint forces being applied to soft tissues rather than bony structures such as the pelvis and shoulders.

Thus, effective occupant protection requires effective occupant restraint which is best accomplished by:

- insuring that the vehicle seat (i.e., the wheelchair) is secured independently and effectively to the vehicle,
- using both upper and lower torso restraints to minimize lower and upper body excursions,
- applying restraint forces to bony regions of the body, such as the pelvis, shoulder, and chest,
- orienting occupants facing forward, and
- providing adequate clear space and energy absorbing vehicle interiors.

Causes of Injury and The Need for Occupant Restraint

For occupants in personal vehicles, effective restraint is provided by the vehicle manufacturer's three-point belt restraint system and the vehicle seat that work together to control occupant kinematics and allow the occupant to "ride down" the vehicle impact deceleration. For front-seat occupants, airbags now offer additional restraint and protection for adults, particularly to the head and chest of belt-restrained occupants in a frontal crash. For small children and infants, there is a variety of forward-facing and rearward-facing child safety seats that, if used correctly, offer a high level of protection in vehicle crashes.

Today, few if any wheelchairs have been designed for use as seats in motor vehicles. Therefore, effective occupant protection can usually be accomplished best if the wheelchair occupant transfers to the vehicle seat and uses the OEM's restraint system. The wheelchair can then be stored and secured more easily with effective tiedown hardware and procedures. For example, it may be possible to transfer small children to one of many types of child restraint seats (CRSs) that comply with FMVSS 213.

There are, however, many adults and children with disabilities for whom transfer is not practical or acceptable because of their size and/or types and degrees of disabilities. For these individuals, the wheelchair must

serve as the vehicle seat, and the typical occupant restraint system intended for use by an occupant in the vehicle seat usually cannot be effectively utilized. In addition, the wheelchair must be secured to the vehicle so that it does not move in a crash and impose forces on the occupant and/or become a hazard to other vehicle occupants in a collision or sudden vehicle maneuver. Thus, for people in wheelchairs, an effective after-market occupant protection system must provide both wheelchair securement and occupant restraint - i.e., **it must be a wheelchair tiedown and occupant restraint system, or WTORS.**

Secure the Wheelchair Independent of the Occupant But not Visa Versa

As indicated in the previous section, one basic principle of crashworthiness design is to not allow the mass of the vehicle seat to increase the restraint forces applied to the occupant during a crash. Adhering to this principle is particularly important, but also problematic, for the person in a wheelchair, since the wheelchair has been designed to be mobile and can often weigh more than 200 lb (91 kg). The principle implies that the wheelchair must be effectively secured with limited movement during a crash. Also, the wheelchair must not tip over, collapse, or break-apart in a manner that could injure the user or other vehicle occupants. It also means that the wheelchair tiedown system should secure the wheelchair independent from the occupant. That is, ***the same belts or other devices should not be used to both secure the wheelchair and restrain the occupant***, so that the forces used to secure the wheelchair are not imposed on, and through, the occupant's body. Unfortunately, there are still securement devices in use that function in this manner.

While it important to secure the wheelchair independent of the occupant, this does not mean that the occupant should be restrained independent of the wheelchair. In fact, the opposite situation, where occupant restraints (i.e., the lap belts and the lower anchorage of the shoulder belt) are anchored to the wheelchair or to the tiedown components as near to the hip of the occupant as possible, is preferred. While this **integrated** configuration for the occupant restraint and wheelchair tiedown will produce higher forces on the vehicle anchor points for wheelchair tiedown, and on the tiedown system, dynamic testing has demonstrated that such forces can be effectively managed with reasonable hardware and components. More importantly, the integrated occupant restraint approach offers enhanced occupant protection by improving the fit of the occupant restraints to the wheelchair occupant, by reducing the potential for submarining under the pelvic belt, and by eliminating the possibility of the wheelchair mass adding to the forces applied to the occupant. The use of integrated occupant restraints also reduces the level of intrusion into the occupant's personal space required during placement of the occupant restraint system on a wheelchair-seated passenger. Also, integrated occupant restraints offer the potential for a higher level of independent use of the restraint system by the wheelchair occupant.

Provide Upper and Lower Torso Restraint

Since the purpose of an occupant restraint system is to minimize, and ideally prevent, contact of the occupant's body with vehicle interior structures, both upper and lower torso restraints are required to reduce knee, chest, and head excursions in a crash environment. While a properly positioned pelvic belt alone will generally prevent an occupant from being ejected from the vehicle or from being thrown about inside, the torso will still flex forward in a frontal crash, allowing the chest and head to undergo relatively large excursions, increasing the likelihood of impact with vehicle interior components, or with other nearby occupants and wheelchairs. For wheelchair-seated occupants who lack upper torso and arm strength, this can be a problem even in low level impacts or emergency braking.

For small children, the optimal restraint system is a four- or five-point harness that is integrated into, and securely attached to, the seat frame of the wheelchair, as is done in child restraint systems. Recently, several wheelchair manufacturers have implemented harness restraints into wheelchairs designed for smaller children for whom the body mass and resulting occupant restraint forces are relatively low. However, this approach is generally not possible with wheelchairs intended for larger children or adults, due to strength limitations of current wheelchair seats and seatbacks. In these cases, a vehicle-anchored three-point belt offers the next best level of protection, until, and unless, wheelchair designs are improved and strengthened to handle pelvic restraint, or pelvic and shoulder restraint forces. (Note: changes in wheelchair design based on ANSI/RESNA WC/19 will hopefully change this situation in a few years)

Apply Forces to Bony Structures of the Body

An important principle that has often been ignored in the transportation of wheelchair-seated occupants is to **apply restraint forces to the bony regions of the body and not to the soft tissues, such as the abdomen**. For a pelvic belt, this means keeping the angle at 30 degrees to the horizontal or greater, and preferably at 45 degrees or greater, so that it has a higher probability of staying over the bony pelvis in a crash. Shoulder belts should be positioned so that the forces are applied across the clavicle or collar bone, as well as the chest. They should connect to the lap belt near the hip of the occupant rather than near the center of the body, so that the shoulder belt does not pull the lap belt up onto the soft abdomen during impact loading.

Postural Supports

Various types of postural belts and lightly padded hardware components are often attached to the wheelchair to provide support and positioning stability for the wheelchair occupant. Belts are often wrapped around the back of the wheelchair at the level of the pelvis, abdomen, or chest, and are connected by light-duty fasteners to the wheelchair frame. Such postural support belts and components should not be relied on for restraint

in a moving vehicle unless they comply with relevant parts of SAE J2249. Although there are not yet standards for postural accessories, product designers should attempt to incorporate break-away features and eliminate sharp metal inserts in lateral thoracic supports and headrest components in future designs. Also, close fitting accessories, such as, "subasis" pelvic bars and knee blocks could reduce the effectiveness of the pelvic belt, and cause unnecessary injury to the wheelchair occupant in a crash situation.

Orient Occupants Facing Forward in the Vehicle

It has been well established by numerous studies of real-world, injury-producing crashes that over fifty percent of motor vehicle crashes resulting in serious and fatal injuries have the principal direction of impact toward the front of the vehicle. These statistics are the basis for forward-facing, high-back, padded seats in school buses manufactured after 1976, as required by Federal Motor Vehicle Safety Standard 222. However, wheelchair-seated students and adult passengers in public transit and personally licensed vehicles have often been transported backed up to the side wall of the bus facing the aisle, with several wheelchairs aligned next to each. From an occupant-protection standpoint, this side-facing orientation is probably the least preferred direction in terms of risk of injury if there is a frontal crash or sudden deceleration of the vehicle. Not only is the human body less able to withstand lateral loading and twisting that results from forces directed laterally to the occupant, but the upper torso restraint becomes largely ineffective, or even a source of injury to the neck. Furthermore, the wheelchair frame is in its weakest orientation to absorb loads imposed by a frontal crash.

It has long been recognized that the safest orientation for a vehicle occupant in a frontal impact is rearward facing if a properly designed, energy-absorbing structure is provided to dissipate and distribute impact loads over the occupant's back, shoulders, and head. However, implementing an effective rear-facing restraint and tiedown system for wheelchair-seated occupants is generally considered to be too costly and impractical. Furthermore, for many wheelchair designs, it is extremely difficult, if not impossible, to achieve good placement of the back support in close proximity to the wheelchair backrest. Finally, it is generally considered to be unacceptable for wheelchair-seated travelers to face rearward when all, or most, other occupants are facing forward.

Although potentially more costly because of reduced occupant seating and wheelchair-occupant capacity, a significant step toward improving occupant protection for people with disabilities can be made by facing the wheelchair forward and by providing adequate spacing between wheelchair stations and other occupants or structures. Facing wheelchair occupants forward instead of sideways may have the additional benefit of improving ride quality through a reduction in lateral *body* movement associated with vehicle acceleration and deceleration, and elimination of problems of disorientation and nausea associated with viewing the passing scenery through the opposite-side windows.

Provide Adequate Clear Space and Energy-Absorbing Interiors

Because no occupant restraint system will completely prevent occupant movement, it is important to provide adequate clear space around wheelchair-seated occupants, in addition to providing an effective occupant-restraint system. Also, vehicle structures near wheelchair-seated travelers should be padded with energy-absorbing material of sufficient thickness and density to reduce the possibility of injury should contact occur (note: FMVSS 201 provides performance information on padding material). If possible and feasible, rigid trays or other equipment attached to the wheelchair, should be removed and secured during transportation so that the hard, sharp edges do not cause injury to the wheelchair occupant, or to other occupants in a crash event.

Larger Vehicles are Better

It is a well established fact that the frequency distribution of crash severities is a function of vehicle mass. Thus, the distribution of crash severities for larger vehicles, such as large school buses and transit vehicles, will span a significantly lower range of DeltaVs (changes in vehicle speed during an impact event) than smaller passenger vans and vehicles. This is so because most vehicle crashes involve impacts into other vehicles, and the higher mass vehicles will be decelerated less than the lower mass vehicle in such encounters.

For these reasons, it is possible to reduce the risk of injury to wheelchair seated occupants simply by transporting them in larger vehicles when the option exists. Transporting users of very heavy wheelchairs in larger vehicles is a particularly good idea since this reduces the likelihood that impact forces will exceed the dynamic strength of either the wheelchair tiedown system or the wheelchair. Also, users who may have particularly low tolerance to injury, will be exposed to less risk if transported in larger vehicles.

IV. SAE J2249: Wheelchair Tiedown and Occupant Restraint Systems

Organization

Following the Scope, Reference, and Definitions sections (Sections 1, 2, and 3) , there are three parts of J2249 that contain the primary requirements and provisions of the Recommended Practice. Section 4 contains requirements that address issues of design intent on keeping with basic crashworthiness principles discussed in the previous section, and with regard to good engineering design practice. Section 5 contains requirements for the WTORS manufacturer with regard to written material, such as instructions and manuals, and with regard to labeling of WTORS assemblies and components. Section 6 contains performance requirements for WTORS that parallel requirements of existing federal standards for OEM vehicle restraints, or that reference specific test methods provided in the appendices of J2249. Included are performance requirements for the frontal impact test, or dynamic strength test (hereafter referred to as the dynamic test), the test for partial and ineffective engagement of WTORS components, and the test for webbing slippage at adjustment devices of wheelchair tiedowns.

Appendices A through D provide normative (i.e., required) test methods and procedures to determine compliance with design and performance requirements contained in the body of the standard. Appendix A specifies procedures for setting up and conducting the dynamic test, Appendix B provides methods for determining compliance with restraint system geometry and adjustment lengths, Appendix C sets forth procedures for determining the potential for partial and ineffective engagement of WTORS components, while Appendix D provides methods for testing adjustment devices of strap-type tiedowns for webbing slippage. Appendix E provides requirements for the surrogate wheelchair that is used in the dynamic test of Appendix A, as well as in the occupant restraint tests of Appendix B. Appendix F is an informative (i.e., not required) appendix that contains additional design and performance recommendations for WTORS manufacturers, such as more specific information about preferred fit of occupant restraints that a manufacturer might wish to include in their instructions to installers, and guidelines for installing WTORS anchorages in sheet metal vehicle flooring.

Overview of the Main Provisions of RP J2249

1. The Scope

The key elements of the scope of SAE J2249 are as follows:

- It specifies design requirements, test methods, and performance requirements for WTORS, requirements for manufacturer's instructions to installers and users, and requirements for product marking and labeling.
- It specifies test procedures and performance requirements for a 48-kph, 20-g frontal impact.
- It specifies test procedures and performance requirements for webbing slippage at adjustment devices of strap-type wheelchair tiedowns, and for partial but ineffective engagement of wheelchair tiedowns and tiedown components.
- It applies to WTORS used with forward-facing wheelchair-seated adults and children to age six.
- It applies to passengers and drivers of personally licensed motor vehicles as well as to passengers of motor vehicles used in public and school transportation.
- It applies to all types of WTORS, including those that use docking-type wheelchair tiedowns.
- It applies to components and subassemblies of WTORS that manufacturers may want to certify as being in compliance with SAE J2249.

It is important to understand that, while SAE J2249 contains a few requirements that apply only to WTORS with specific types of tiedowns, such as docking devices or four-point strap systems, most of the Recommended Practice applies to WTORS that use all types of tiedown devices, as long as they are designed and intended for use with forward-facing wheelchairs and occupants. The only restriction is that the WTORS must include a belt-type occupant restraint system, which can be either the vehicle three-point restraint provided by the vehicle manufacturer (primarily for the situation of a wheelchair-seated driver), or an occupant restraint system that is provided by the WTORS manufacturer. In the latter case, which is strongly encouraged, both upper- and lower-torso restraints must be included in the complete WTORS system. This is done to provide the user with the option to use, and to encourage the use of, a complete and effective occupant restraint system. Obviously the Recommended Practice does not, and cannot, enforce the use of either by individuals or transportation authorities.

The Recommended Practice also allows a manufacturer to certify parts of a WTORS system as being in compliance with J2249 if tested as part of a complete WTORS and accompanied by appropriate documentation (see 5.5 of J2249). This was done in recognition that some manufacturers currently market components of a complete WTORS, such as anchorage track or strap webbing, to replace components of previously purchased WTORS, or for assembly and installation with other WTORS components by the installer or vehicle modifier.

Unlike the comparable ISO WTORS standard (ISO 10542-1 and -2)⁵, SAE J2249 applies to WTORS that are used with children about six years and older, as well as adults (i.e., with a body mass of 22 kg or greater). In general, however, a WTORS must demonstrate that it is strong enough to perform effectively for adults with potentially high wheelchair and occupant masses, since in public and school transportation, it is almost never possible to control the situations in which a particular WTORS product line will be used. A WTORS designed for use with only lighter-weight child-size wheelchairs and occupants can be tested to J2249 using a specific wheelchair. In this case special marking and labeling (see Section 5.1 of J2249) is required on the WTORS components and in the WTORS literature to indicate these limitations, and to minimize the possibility of misuse.

2. References

As is typical in all SAE Recommended Practices, the references are divided into two sections referred to as *Applicable Publications* and *Related Publications*. Applicable publications are referenced in normative sections of the document and are therefore essential to the provisions and requirements of J2249. Related publications are other documents that contain informative material pertinent to the Recommended Practice, or are standards or practices that contain similar provisions.

Applicable Publications are typically divided into *SAE Publications* and *Other Publications*, where, for J2249, *Other* is federal motor vehicle safety standards. In this initial printing of the Recommended Practice, three SAE references were included in Applicable Publications when, in fact, only one reference should be listed. The required reference is SAE J211-2, which gives procedures for filtering transducer signals resulting from the dynamic test of Appendix A. The other two references to J850 and J1834 should be in the Related-Publications section, since they are not referenced in any of the normative parts of SAE J2249. This is being corrected in the 1999 printing of the document.

The two federal standards that are referenced under Applicable Publications are FMVSS 209 and FMVSS 302. The first of these specifies many requirements and associated test methods for *Seat-Belt Assemblies*, such as abrasion resistance of webbing material, belt retractor performance, etc. Those parts of FMVSS 209 that were considered applicable to either occupant restraints or wheelchair tiedowns, or both, are listed in Table 2 of J2249.

The related publications listed in 2.2 of J2249 include numerous SAE publications that deal with crashworthiness design and testing of vehicles and occupant protection systems, as well as closely related standards from the U.S. and other countries, including WTORS and wheelchair standards

⁵ see Appendix A for reference

from Australia, Canada, and ISO. The listing of these related standards and their current status is provided in Appendix H.

3. Definitions

While many of the definitions in this part of the RP are self explanatory, several have been specifically and carefully developed to clarify terminology which is unique to the situation of occupant protection systems that provide both wheelchair tiedown and occupant restraint. Key definitions, as they appear in J2249, are provided in the Glossary section (Appendix B) of this guideline document. The rationale for selected key terms and an explanation of their intended usage follows.

In J2249, the term *restraint* is used only in reference to the occupant and not in reference to the wheelchair which is *secured* or tied down, but not restrained. Also, while both wheelchair tiedowns and occupant restraints may include webbing material, the term *belt* is used only in the context of a length of webbing material in an occupant restraint, while the term *strap* is used to refer to a length of webbing material used in a wheelchair tiedown. Thus, it is incorrect to refer to the tiedown *belt*, or to refer to an occupant restraint *strap*.

Another set of terms that should be noted are those of *anchor point*, *anchorage*, *securement point*, and *end fitting*. Both anchor point and securement point are points or places to which wheelchair tiedowns and occupant restraints may be attached (i.e., they are both attachment points). However, the term *anchor point* is used exclusively in reference to the points on the vehicle, tiedown hardware, or wheelchair to which the object (e.g., the occupant or wheelchair) is being anchored or fastened. Thus, occupant restraints may be anchored to the wheelchair, to wheelchair tiedown components fastened to the vehicle, or to the vehicle itself. Similarly, a wheelchair is generally secured to anchor points on the vehicle (actually to hardware or anchorages fastened to the vehicle).

In contrast, the term *securement point* (or tiedown point) is reserved exclusively for those points or places on the wheelchair which are "grabbed" by the tiedown device or system in order to anchor or secure the wheelchair to the vehicle. Note that people don't have securement points. Thus, a wheelchair may have four securement points for the case of a four-point tiedown system, or it may have only one or two securement points, in the case of a docking-type tiedown. These points are connected by means of the tiedown system or device to the anchor points. Both anchor points and securement points fall into the general category of *attachment points*.

The term *anchorage* refers to the physical hardware that accomplishes the anchoring or connecting to the anchor point, including the hardware that may be fastened to the vehicle (e.g., the tiedown track), as well as the hardware on the tiedown or restraint system that attaches to the vehicle. The term *end fitting* is more general than the term *anchorage* and refers to

hardware that attaches to an anchorage at the vehicle anchor point, as well as to hardware that attaches to the securement point on the wheelchair. In other words, end fittings are the parts of the tiedown or restraint assembly that connect to the wheelchair that is being secured, and that connect to the object to which the wheelchair tiedown or occupant restraint is being anchored. An anchorage (i.e., hardware component) is an end fitting if it is the part of a tiedown assembly that connects and disconnects to the vehicle anchorage without the use of tools, but an end fitting is not an anchorage if it connects to the securement point on the wheelchair. Also, an anchorage installed in the vehicle is not an end fitting.

The definitions in J2249 include several terms related to occupant restraints, most of which are self explanatory (see Glossary). The terms *independent* occupant restraint and *integrated* occupant restraint have been mentioned previously. Strictly speaking, a fully integrated occupant restraint is one for which the anchor points are on the seat or wheelchair, such that all occupant restraint forces (i.e., upper and lower torso) are transferred to, and through, the wheelchair. Similarly, a partially integrated occupant restraint would be one for which only the pelvic belts are anchored to the wheelchair with the shoulder belt being anchored to the vehicle. However, for purposes of this standard, a more liberal definition has been used. This definition considers an occupant restraint to be integrated if the pelvic belt anchors to tiedown components that are located close to, or attached to, the wheelchair, as is the case with the Q'Straint system and a version of the Kinedyne system.

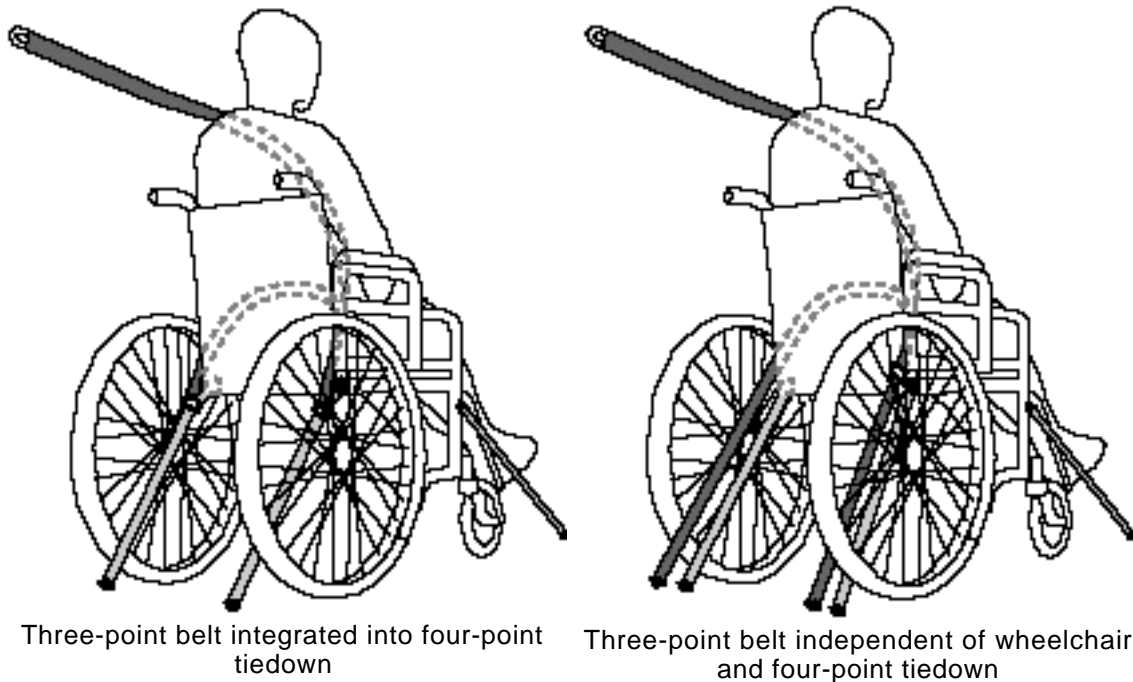

Figure 1 - Integrated (left) and independent (right) three-point belt restraint and four-point, strap-type tiedown.

Figure 1 illustrates this more liberal definition of an integrated occupant belt restraint with a four-point, strap-type tiedown compared to an independent occupant restraint that anchors to the vehicle.

The term *test wheelchair* refers to the wheelchair that is used to evaluate the WTORS in the dynamic test of Appendix A and in the seat-belt geometry and adjustment-length tests of Appendix B. In general, the test wheelchair will be the surrogate wheelchair, which is abbreviated as SWC. The surrogate wheelchair is specified in Appendix E as a rigid wheelchair-like structure with a total mass of 85 kg and dimensions and design features as indicated and illustrated in Figure 2. However, as previously indicated, J2249 allows for testing a WTORS that is uniquely designed for, and exclusively to be used with, one particular type or size of wheelchair. In this case, the actual production or prototype wheelchair is used in the tests. Therefore, the term *test wheelchair*, rather than surrogate wheelchair, is needed to generically reference the wheelchair used in the tests of J2249.

At the time the document was written, there were two primary types of WTORS in use in the United States that are considered to provide effective wheelchair securement --those that use four-point strap-type tiedowns and those that use docking-type systems (see Glossary for complete definition). The latter are usually more expensive, but may provide automatic wheelchair tiedown without the need for an attendant or assistant. They are therefore primarily used by wheelchair-seated drivers of vans, but may also be used by transit vehicle passengers to save time on fixed routes. An example of the latter is the experimental docking system developed by Oregon State University in which two U-shaped brackets attached to both sides of the back of the wheelchair dock with two spring-loaded clamps when the wheelchair is backed into a floor-mounted stanchion. However, docking systems have not found wide acceptance in public transit due to the lack of a standardized method for attaching to the wide range of wheelchair sizes and designs in the marketplace.

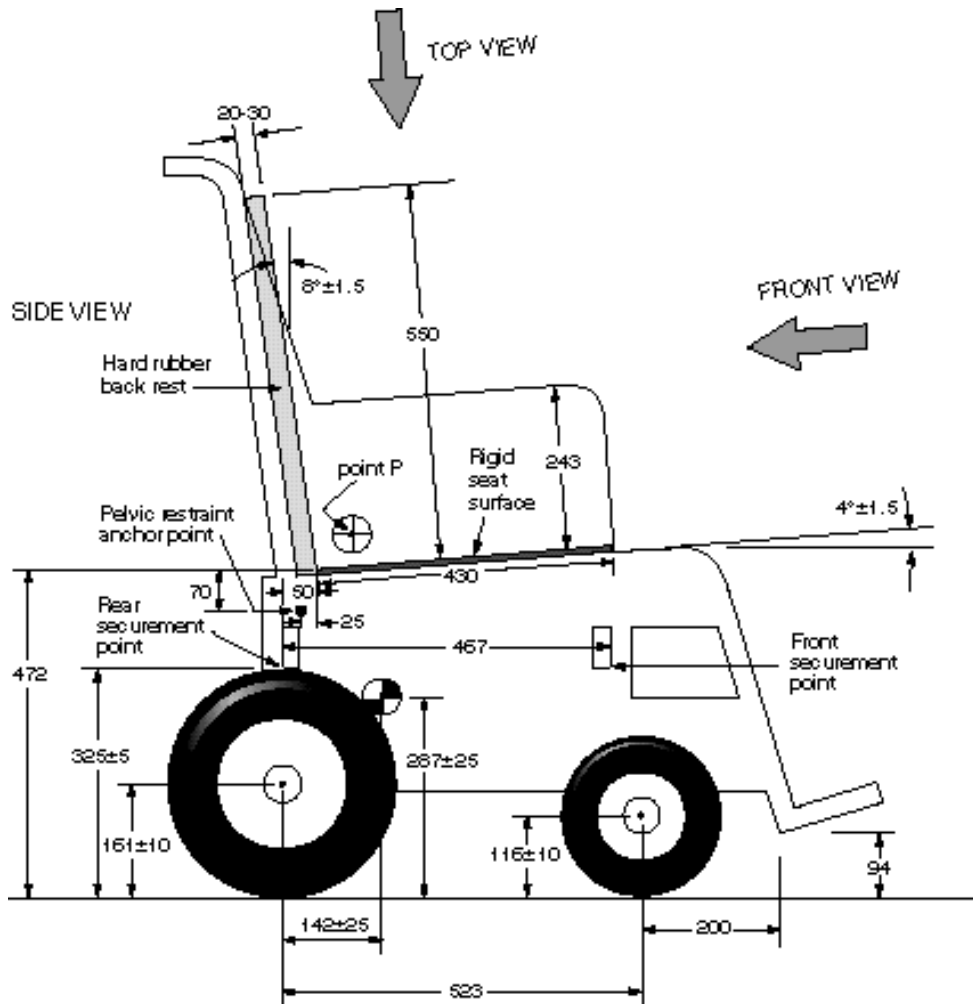

Figure 2 - Side-view illustration of the surrogate wheelchair.

Four-point, strap-type tiedowns are more generally applicable to a range of wheelchair sizes and types without the need for wheelchair add-on brackets, although brackets are a good idea if they improve accessibility to securement points on the wheelchair. In this regard, the strict definition of a four-point tiedown requires four separate securement points on the wheelchair and four separate anchor points on the vehicle and/or on tiedown components fastened permanently, or attached temporarily, to the wheelchair. Therefore, when a four-point strap-type tiedown is used to secure a wheelchair such as a powered scooter, where both front strap assemblies may be attached to the base of the steering tiller, this does not strictly comply with the definition of a four-point tiedown since there are really only three securement points on the wheelchair. Similarly, if two front or two rear strap assemblies anchor to the same anchor point and anchorage hardware on the vehicle, the system is not, strictly speaking, a four-point tiedown system.

4. WTORS Design requirements

Section 4 of J2249 contains requirements for WTORS that address the “design intent” of the WTORS manufacturers. It is in this section that the essential elements of good engineering practice and basic crashworthiness design principles are set forth in the requirements for WTORS. The section is divided into three parts based on whether the requirements apply to both the tiedown and restraint system subassemblies (complete WTORS), to only the tiedowns, or to only the occupant restraints.

4.1 Complete WTORS

As noted previously under Scope, one of the primary goals of J2249 is to encourage the design and marketing of complete WTORS that provide for both wheelchair securement and occupant restraint. The design requirements set forth in J2249 that apply to both the components, separate assemblies, and total assembly of the complete WTORS, are the following:

WTORS shall:

- a) be for use with only one wheelchair and one occupant at a time,
- b) not require components of wheelchair tiedowns and occupant restraints to pass through the wheels of a wheelchair,
- c) provide for release of both the wheelchair and the occupant within sixty seconds by a single attendant or wheelchair user without the use of tools,
- d) not require removal of wheelchair frame material, drilling into the wheelchair frame, deformation of the wheelchair, welding, or the use of an adhesive process, during installation, unless the WTORS is intended for a specific wheelchair and the modifications are approved by the wheelchair manufacturer,
- e) once installed, be operable without tools,
- f) include only hardware and fittings that are permanently connected to the WTORS or a WTORS subassembly,
- g) be designed to prevent unintentional loosening of all threaded fasteners,
- h) include a manual override in case of power failure for any power-operated mechanisms of tiedowns or restraints, and
- i) include anchorage fasteners and hardware, and/or specifications for such hardware, that are based on the material, size, and quantity of anchorage fasteners used in the simulated frontal impact test of Appendix A.

The design requirements of this section are applicable to the complete WTORS or, in other words, to both the tiedown and restraint portions of a WTORS. In general, these requirements are straight forward and do not require further explanation. The intent is to ensure that a WTORS and its various components are available to the user throughout the life of the WTORS, and so that proper use or installation of the system does not compromise the integrity of the wheelchair frame (i.e., by drilling holes in, and thereby weakening frame members). Also, the design intent should include ease of use in securing the wheelchair and restraining the occupant

(i.e., no tools required), and, in the case of power-operated tiedowns, provision for effective emergency release in the event of a vehicle power failure (i.e., engine cutoff and/or dead battery).

4.2 Wheelchair Tiedowns

Design requirements for the wheelchair tiedown components and assemblies are that the tiedown shall:

- a) not depend on the wheelchair brakes,
- b) be designed so that securement of the wheelchair is accomplished by the tiedown only and not by the occupant restraints,
- c) provide a means to eliminate free movement of the wheelchair without the use of tools,
- d) if the WTORS includes a four-point strap-type tiedown, each strap assembly shall provide for manual adjustment in length without the use of tools, such that the adjustment ranges of front and rear straps enable achieving the minimum and maximum lengths indicated in Table 1 (see below), with at least 25 mm of webbing extending from the adjustment mechanisms,
- e) have securement-point end fittings of four-point tiedowns that are compatible with the securement-point opening geometry and the cross section of the securement-point structural member of the surrogate wheelchair illustrated in Figure E.4, and
- f) include a device to indicate, by visual or auditory means, when a docking-type tiedown is properly engaged.

Table 1
Minimum Adjustment Ranges for Four-Point Tiedown Straps

Strap Assembly Location	Minimum Length* mm (in)	Maximum Length* mm (in)
Rear	485 (19)	740 (29)
Front	410 (16)	710 (28)

* Length is defined as the straight-line distance from the point of intersection of the tiedown end fitting with the wheelchair securement point, to the point at which a straight line along the length of the strap assembly intersects with the wheelchair ground plane when set up as specified in A.6.

+ See F.14 and Figure F.5 of Appendix F for rationale.

Clause (a) states that the wheelchair brakes should not be required for proper functioning of the wheelchair securement device or securement process (e.g., the brakes should not be relied on even to hold the wheelchair in position for docking). This requirement recognizes that braking effectiveness can vary widely across wheelchairs, wheelchair types, and even for the same wheelchair over time, and that brakes do not offer adequate securement in a crash, or even in normal or emergency vehicle maneuvering.

Clause (b) is the very important requirement discussed under *Basic Principles* that wheelchair securement must be achieved independent from occupant restraint, so that the occupant does not experience additional forces due to all, or part, of the wheelchair mass. Clause (c) recognizes that slack or free-play in a system can result in total system or component failure under impact conditions, and therefore must be eliminated in all types of tiedown systems (docking or strap type) if effective securement is to be available when needed. This requirement is necessary since the dynamic test of Appendix A is a single test, at a single setup condition, and will therefore not evaluate this aspect of performance for all possible scenarios of tiedown free-play or slack. In addition, slack or free-play can increase fatigue and discomfort to the wheelchair-seated passenger. Clauses (d) and (e) of this section apply to WTORS that use four-point strap-type tiedowns which, as previously noted, are effective and commonly used in situations where there is a need to secure a range of wheelchair types. If properly designed, these tiedown systems have been demonstrated to be very effective during frontal impact loading with forward-facing wheelchairs. A primary requirement is that such systems provide four adjustable-length tiedown assemblies that can be shortened and lengthened to lower (minimum) and upper (maximum) bounds on strap length. The minimum and maximum lengths for the tiedown assembly specified in Table 1 are based on expected locations of the four securement points on wheelchairs, expected locations (i.e., distances between) of anchor points in vehicles, and maximum and minimum lengths of four-point tiedown assemblies that were considered to be reasonable and acceptable. This is illustrated in Figure 3.

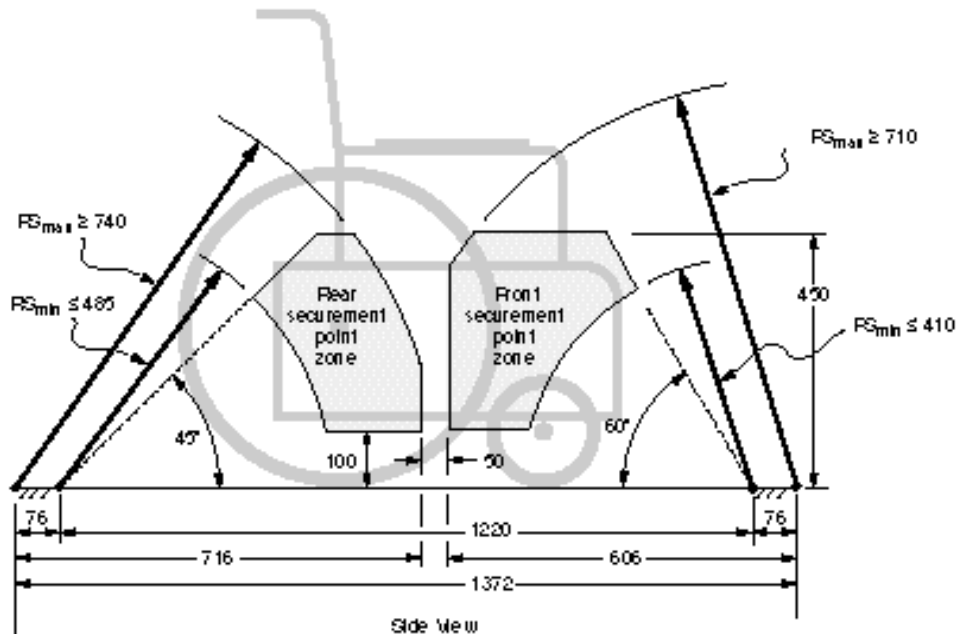

Figure 3 - Rationale for length adjustment ranges of strap assemblies used in four-point tiedowns.

Note: Securement points should be located only on wheelchair frame members and components, and not on wheels or other movable or removable parts of the wheelchair.

The minimum length requirements are based on the consensus of current WTORS manufacturers with regard to a reasonable lower bound for strap assembly length with sufficient strength to pass the frontal impact test of Appendix A, and that include anchorages, hook-type securement-point end fittings, manually operated adjustment and tensioning mechanisms.

The maximum length requirements are based on manufacturer and transportation personnel consensus with regard to acceptable upper bounds on strap assembly length to minimize cumbersome use in the field (i.e., too much length becomes unwieldy). The requirement is that the strap assemblies of the four-point tiedown system manually adjust in length to achieve the minimum and maximum values in Table 1. A WTORS that provides for adjustment of tiedown assembly lengths beyond the minimum and maximum values given in Table 1 will also comply with this requirement.

In the comparable ISO WTORS standard (ISO 10542-2), four-point, strap-type tiedowns need only have two front or two rear adjustable-length strap assemblies (i.e., two can be fixed in length), as long as there is provision for fore/aft anchor point adjustment (e.g., an anchorage track that runs fore/aft in the vehicle). Such systems are, however, not comparable in their ability to deal with front and rear securement-points in the zones shown in 3. Furthermore, the length requirements for the fixed strap assemblies and the range of fore/aft anchor-point adjustment have not been established. Therefore, such four-point, strap-type tiedown systems are not considered to be in compliance with SAE J2249.

The second requirement of four-point, strap-type tiedowns is that the end fitting of each strap assembly be compatible with the securement points on the surrogate wheelchair. The required geometry is specified in Figure E.4 of J2249 and Figure 4a below. While Figure 4a is in the current version of J2249, it will be replaced by Figure 4b that shows a more appropriate geometry for the securement point. This geometry is based on deliberations in ISO, SAE, and CSA standards development. The opening geometry is a 25 mm by 60 mm slot and is based on the need to attach to wheelchairs using both hook and strap-type end fittings of current four-point tiedown systems. The tiedown end fitting must also effectively engage with the 30-mm diameter structural members of wheelchairs. This dimension is based on the maximum expected cross-section of wheelchair tubing that might serve as a securement point on many wheelchairs. (Note: Since ANSI/RESNA WC/19 specifies a maximum cross-section of wheelchair securement points of 26 mm, future tiedown end fittings will hopefully not be required to engage with the larger 30-mm diameter cross-section. Therefore, this requirement may be modified in future versions of J2249 after most wheelchairs have securement points that comply with ANSI/RESNA WC/19).

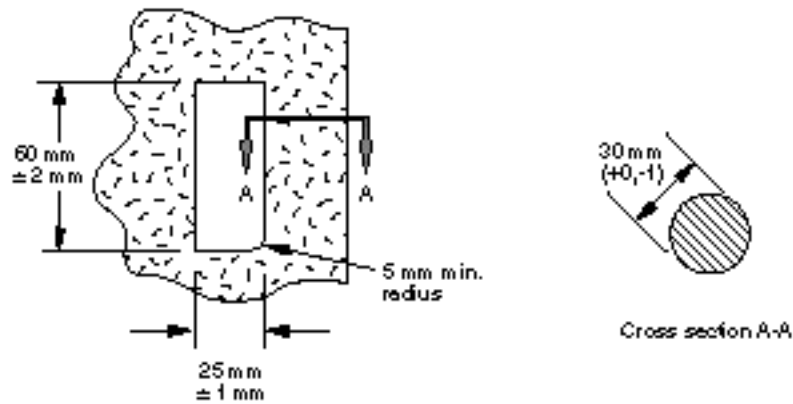

Figure 4a. Dimensions of wheelchair securement points on the surrogate wheelchair and required engagement geometry for securement-point end-fittings of four-point strap-type tiedowns in current version of J2249.

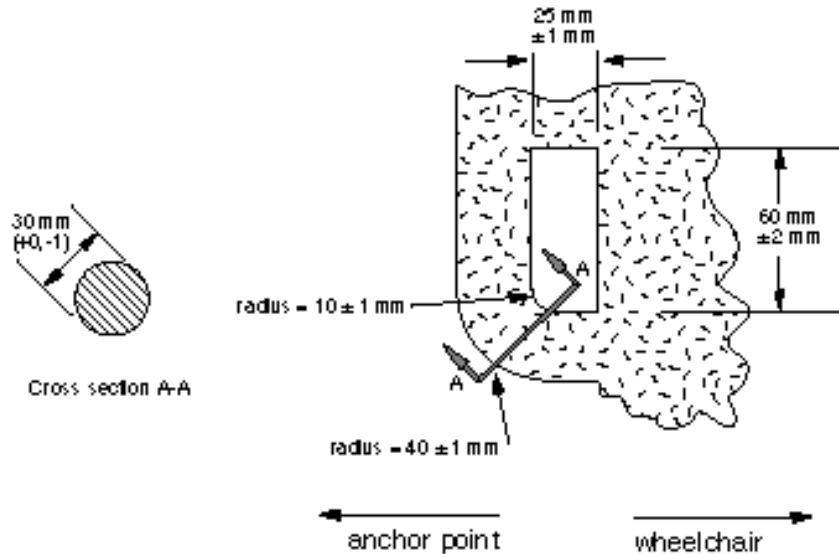

Figure 4b. Modified and improved drawing of surrogate wheelchair securement points to be included in next version of J2249 (from ISO 10542-2).

Clause (f) in this section applies only to docking-type tiedown systems. The requirement is that such devices include a mechanism that indicates when the system is properly engaged, so that the independent wheelchair user knows when the wheelchair is effectively secured. To some extent, the concern about improper or ineffective engagement of a docking-type system is addressed by the Test for Partial Engagement of Appendix C. However, Appendix C simply provides for testing possible and foreseeable scenarios of improper engagement during WTORS testing and evaluation. Whereas Clause f requires an additional method of visual or auditory verification of proper engagement.

4.3 Occupant Restraints

The requirements of Section 4.3 apply to the occupant restraint portion of the WTORS, not the wheelchair tiedown. They address several issues related to design intent regarding proper fit of restraint systems to potential users, as well as to accommodating the range of potential occupant sizes who may use the system in a public vehicle.⁶

The introductory statement to this section of J2249 allows the WTORS manufacturer to design and market a wheelchair tiedown system with the intention that the wheelchair user will make use of the vehicle manufacturer's three-point belt restraint system. This allowance has been included primarily for the situation of wheelchair-seated drivers, who are currently known to use vehicle-installed restraints, perhaps with some modifications to make the system passive (i.e., automatically in place) and so that the belt will achieve a reasonable fit to the driver seated in a wheelchair. Even in these driver situations, however, it is strongly recommended that the WTORS manufacturer include a specially designed and tested occupant restraint system, so as to better achieve the objectives of effective occupant restraint for a wheelchair-seated driver.

The requirements set forth for occupant restraint systems provided by the WTORS are the following:

- 4.3.1 The occupant restraint portion of the WTORS shall include both pelvic and upper torso restraints.
- 4.3.2 Occupant restraints may be designed to anchor directly to the vehicle, to components of the wheelchair tiedown, or to tiedown components fastened to the wheelchair. Occupant restraints shall not be designed with anchorage's that rely on the transmission of restraint loads through the wheelchair structure unless the WTORS is designed for a specific wheelchair and the WTORS meets the requirements of 6.2 when the combination of wheelchair and WTORS is tested according to Appendix A.
- 4.3.3 The lengths of pelvic and upper torso restraints shall be manually adjustable without the use of tools.
- 4.3.4 When the WTORS is set up and measured as specified in Appendix B, pelvic restraints and, if applicable, their anchor points or guide points, shall:
 - a. achieve side-view projected angles that fall within the zone shown in Figure 5b,
 - b. achieve projected rear-view angles and locations within the zones shown in Figure 5a, and
 - c. provide sufficient length adjustment to allow the pelvic restraint, measured from anchor point to anchor point, to be both increased and decreased by 200 mm with at least 25 mm of webbing extending through the restraint end fittings at all times.

⁶ In general, J2249 was written with the assumption that the WTORS manufacturer does not have control on the end use of their product, and that WTORS will be used in situations where a range of user sizes must be accommodated.

- 4.3.5 When the WTORS is set up and measured as specified in Appendix B, upper torso restraints shall provide for sufficient length adjustment to extend an additional 200 mm, and shorten by 300 mm with at least 25 mm of webbing extending through the restraint end fittings at all times.
- 4.3.6 For WTORS that include upper-anchor points or upper-guide support structures for shoulder or harness restraints, the locations of these anchor points or supporting structures shall:
- be sufficiently adjustable in height to be located at or above the shoulder levels of the intended users, or
 - be located at least 1100 mm above the wheelchair ground plane so as to be near or above the shoulder height of wheelchair seated occupants.
- Note 1: The anchor point may be located below 1100 mm if an upper-guide support is located at or above 1100 mm.
- Note 2: Although FMVSS 210 allows for the upper torso restraint anchor points to be located a significant distance below the occupant's shoulder level, such locations are considered to be undesirable and not in compliance with this recommended practice, since they could result in downward loading on the occupant that can produce spinal injuries.
- 4.3.7 The junction of the shoulder and pelvic restraints of three-point restraints shall be located not less than 150 mm from the ATD centerline when installed as specified in Appendix B.
- 4.3.8 An airbag shall be used only as a supplementary occupant restraint in conjunction with a wheelchair tiedown and belt-type occupant restraint that comply with the requirements of this recommended practice.
- 4.3.9 Performance of the WTORS shall not depend on an airbag to comply with this recommended practice.

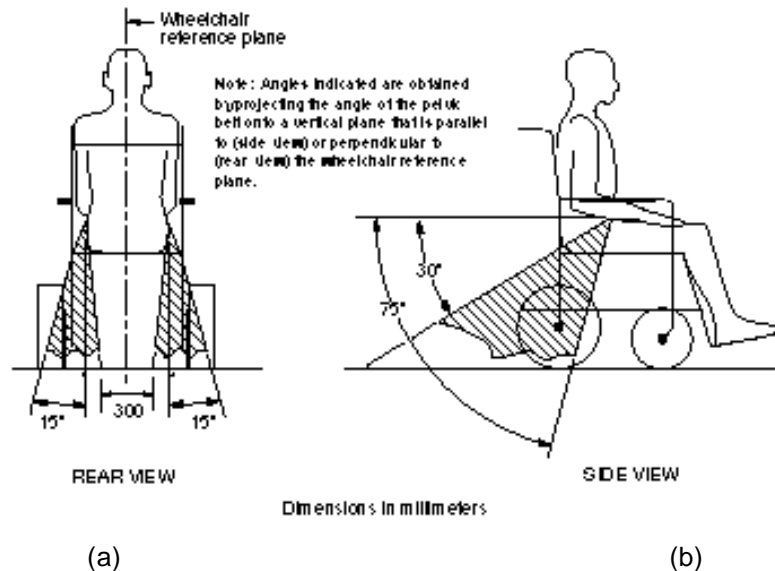

Figure 5 - Range of required angles and locations for pelvic restraints and pelvic-restraint anchor points. Note that angles indicated are obtained by projecting the angle of the pelvic restraint onto a vertical plane parallel to the wheelchair reference plane (side view), or onto a vertical plane that is perpendicular to the wheelchair reference plane (rear view).

The first requirement (4.3.1) is a restatement of the fact that both upper- and lower-torso belts are needed to minimize the possibility of occupant contact with interior vehicle components or with other occupants and wheelchairs. The second requirement (4.3.2) is primarily a statement about the locations of the anchor points for which the WTORS is designed. While a belt restraint that anchors to the seat or wheelchair is generally considered to offer improved belt fit for the user, this clause recognizes that most wheelchairs in use today are not designed for, and would not be able to withstand occupant restraint forces. Thus, the requirement states that the design intent of the WTORS must be for a belt-type occupant restraint system to anchor to the vehicle or to tiedown components that may be either fastened to the vehicle or to the wheelchair. Note that the later may be fastened permanently (e.g., bolted) to the wheelchair, or fastened temporarily during transit, as is the case with the Q'Strait system, where the pelvic belt anchors to the rear tiedown straps that are hooked to the wheelchair frame.

The only exception to this (i.e., to allowing a WTORS to have occupant restraints designed with the intent of anchoring to the wheelchair) is when the WTORS is designed for use with a specific wheelchair and that wheelchair is used as the "test wheelchair" in the frontal impact test of Appendix A. In this case, the frontal impact test is really a systems test (i.e., testing the wheelchair plus the WTORS together. This was done so that compliance with the standard makes a consistent statement about the dynamic strength of a WTORS that complies with the standard -- i.e., that it performed effectively under dynamic loading with an 85-kg wheelchair. The comparable ISO standard (ISO 10542) does not allow such systems tests within Part 1 of the standard, but rather only allows for conducting the frontal impact test with the 85-kg surrogate wheelchair. In ISO, the system test for WTORS that transfer occupant restraint forces to the wheelchair is being accomplished in ISO 10542-5, which is now under development. In either case, the issue comes down to requirements for labeling of WTORS with these types of restraint anchorages, so that they are only used with wheelchairs that have been appropriately tested. Eventually, all wheelchairs that comply with ANSI/RESNA WC 19 will meet this requirement for the pelvic-belt anchor points being on the wheelchair. It will then be possible to modify SAE J2249, to allow testing of all WTORS using the surrogate wheelchair, whether or not they transfer occupant restraint anchorage forces to the wheelchair.

Clauses 4.3.3 through 4.3.7 deal with the fit and accommodation of belt-type occupant restraints to the range of potential users and for the range of foreseeable anchor point configurations in the real world. The first of these (4.3.3) is a requirement that, like all belt restraints installed by vehicle manufacturers, belt restraints of WTORS must be manually adjustable. This requirement is also covered by the fact that restraint systems used in WTORS must comply with FMVSS 209 (see 6.1). The test of Appendix B (4.3.4 and 4.3.5) provides a check on the geometry and adjustment lengths of WTORS for a nominal set of conditions using the

surrogate wheelchair and an adult-size crash dummy or ATD. When setup according to these procedures, the angle of the pelvic belt must fall between 30 and 75 degrees to the horizontal when viewed from the side.⁷ The preferred range of pelvic-belt angles is 45 to 75 degrees because steeper angles reduce the probability of occupant submarining under the pelvic belt, a phenomenon that can produce serious and fatal injuries to abdominal organs in a severe frontal crash. However, the standard allows the pelvic belt in these nominal setup condition to be as low as 30 degrees, which is compatible with federal safety standards (i.e., FMVSS 209).

Similarly, the requirement of 4.3.7 that the junction of the shoulder belt with the pelvic belt, illustrated in Figure 6, of three-point restraints be at least 150 from the centerline of the midsize male ATD is related to the concern of the occupant submarining under the lap belt, in this case because of the pelvic belt being pulled off the bony pelvis by upward force from the shoulder belt. The junction of the pelvic and shoulder belts will ideally be near the hip of the occupant, with the shoulder belt fitting properly across both the chest and shoulder, so that the pelvic belt is not pulled upward by the shoulder belt.

Since the junction of the shoulder belt and pelvic belt is usually a fixed distance from the pelvic-belt anchor point, and since a wheelchair station may be used with a range of occupant and wheelchair sizes, it may not be possible to achieve the ideal location of this junction for all users (another good reason for using wheelchair-anchored pelvic restraints that are fit to the individual user). However, the requirement of 4.3.7 provides a check of design intent for a nominal adult configuration. It is generally better if the shoulder-pelvic belt junction point is further from the centerline, and even below the hip, than closer to the centerline, and this will be the case for most occupants if the conditions of the test are met when there is a fixed distance between the pelvic-belt buckle and the shoulder-belt junction.

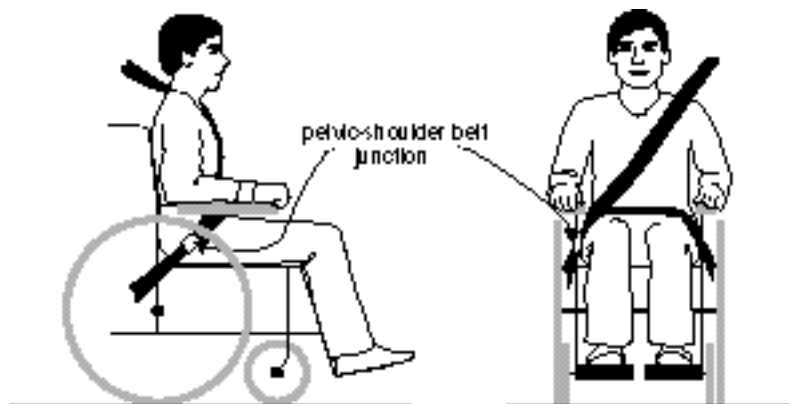

Figure 6 - Illustration of pelvic-belt/shoulder-belt junction.

⁷ In the current version of SAE J2249, the allowed angle is incorrectly specified as 45 to 75 degrees. This will be corrected in a future edition.

For the pelvic belt, the adjustment length requirement is that the belt assembly be able to lengthen and shorten by 200 mm (about 8 in) from the nominal length when fit to the midsize-male ATD seated in the surrogate wheelchair. These length adjustments are needed because of differences in wheelchair dimensions (e.g., heights of the seat above the ground) and because of differences in occupant size. Since J2249 applies to WTORS that are used with children as well as adults, these should be considered minimum adjustment requirements. Depending on the wheelchair and WTORS designs, a reduction in length of 200 mm may not be sufficient to provide a snug fit to some children. Thus, it may be necessary for WTORS manufacturers to offer additional adjustment range, or special pelvic belt options, when it is known that smaller children need to be accommodated.

For the upper-torso belt adjustment range (4.3.5), the test setup specified in Appendix B requires that the system be installed using upper anchor points or guide points that are located at worst-case positions of the anticipated range of foreseeable anchor-point locations in actual vehicles. For example, this location is representative of an anchor point that is located above and behind the windows of a bus, since this may be the only available place where a suitably strong vehicle structure for the anchor point can be found. The figures in Appendix F of J2249 illustrate expected real-world anchor-point zones, where the worst-case locations are the highest corners in these zones. The requirements are that an additional 200 mm (8 in) of lengthening be provided, primarily to account for occupants who are larger than the average U.S. male (76.3 kg), and that it be able to shorten by 300 mm (12 in) to fit smaller people and for lower anchor points.

For WTORS that provide a structure for the upper-torso anchor point or guide point, such as a triangulated tubular structure that is installed in the vehicle as an after-market component, clause 4.3.6 addresses the height of these anchor points. Ideally, such structures will provide for adjustment of the anchor-point height, so that the anchor point can be established at, or a few inches above, the wheelchair users' shoulders. However, if an upper anchor point provided with the WTORS is at a fixed height, Part b requires that it be located a minimum height of 1100 mm above the vehicle floor or wheelchair ground plane. While this may be significantly higher than the shoulders of some wheelchair-seated occupants, it is better that it be close to, or above, the shoulder height of all wheelchair occupants, than significantly below the shoulders of some users. Based on a database of wheelchair seat heights (not including cushions) and data on seated shoulder heights, it has been estimated that the height of the shoulder of an average size U.S. male will be about 1100 mm above the floor (see Table F2 in Appendix F of J2249).

In reference to this shoulder anchor-point-height requirement, it should be noted that FMVSS210 (seat-belt anchorages) allows the upper anchor

points of upper torso belts to be located so as to produce a downward (to the horizontal) angle of 30 degrees. During the development of J2249, this federal requirement was referenced by one WTORS manufacturer as reason to change or remove the minimum height requirement for fixed after-market anchor points. However, the SAE Task Group considered the federal standard to be outdated in terms of good restraint system design practice, and therefore rejected this more liberal geometry. The concern is that if the upper torso belts are directed downward to their anchor point after passing over the shoulder, this will generate downward forces on the occupant's spine that can produce spinal-cord injury.

The last two requirements of this section address the issue of design intent with respect to the use of airbag restraints. As indicated in the Scope of J2249, a WTORS that complies with J2249 must use, and be impact tested with, a belt-type occupant restraint. Clauses 4.3.8 and 4.3.9 reaffirm this requirement by indicating that an airbag shall not be used without a belt-type occupant restraint, and shall not be used to assist the performance of the belt restraint in the frontal-impact test of Appendix A.

5. Requirements for Instructions, Documentation, and Labeling

Section 5 of J2249 contains requirements for the written documentation that WTORS manufacturers must provide to installers and users about their products, as well as statements and markings that must be included on the WTORS and WTORS component' labels, or in presale literature. More specifically, these requirements encompass:

- identification and labeling of WTORS assemblies and components
- instructions and warnings for installation of the WTORS in a vehicle,
- instructions and warnings to users of the WTORS, and
- requirements for statements in presale literature.

It will be noted that many of the statements that comprise the requirements of this section use the word "should" rather than "shall." For example, 5.20 requires that the WTORS manufacturer provide a statement in the instructions to the installer that "all vehicle padding *should* comply with the flammability requirements of FMVSS 302." The reason for using should instead of *shall* in this statement is that the requirement is for the WTORS manufacturer to provide the statement, not to enforce its implementation, which is obviously impossible and therefore inappropriate to word in a normative manner J2249. Note that the introductory statement to 5.2 says that "Manufacturers of WTORS *shall* provide written instructions for the installer that include:" This is the mandatory part of the requirement.

5.1 Identification and Labeling

The requirements in J2249 for product identification and labeling are as follows.

Primary WTORS components and subassemblies shall be permanently and legibly marked with:

- a) manufacturer's name or trademark,
- b) month and year of manufacture with the month indicated by the name or a recognized abbreviation and the year indicated by at least the last two digits,
- c) manufacturer's model and part number or an equivalent identification code,
- d) other information that may be necessary to identify a particular product in the event that a recall or special inspection becomes necessary,
- e) the name and location of each detachable WTORS component (e.g., right-rear tiedown, shoulder restraint, pelvic restraint, etc.), and
- f) the notation that the WTORS complies with SAE J2249, and for WTORS impact tested according to Appendix A with a specific production or prototype wheelchair rather than the 85-kg surrogate wheelchair, the make, model, and name of the specific wheelchair, along with the mass of the wheelchair and ATD used in the test.

These requirements pertain to the labeling or marking of the physical pieces, components, and subassemblies that comprise the WTORS. The manufacturer's name or trademark, date of manufacture, and model plus part number are important for determining the age and source of a WTORS system with regard to potential replacement. These markings will also be useful for identifying WTORS or WTORS components that may need to be recalled in the event of a product defect. However, if, in the judgment of the WTORS manufacturer, these are not sufficient for recall and replacement purposes, 5.1d requires that additional information, such as manufacturer lot number, also be provided.

Statement 5.1e requires that the separate functional components of a WTORS be clearly labeled as to their intended purpose. For example, the separate parts of the occupant restraint should be labeled "pelvic belt (left)", "pelvic belt (right)", and "shoulder belt." Also, for a WTORS that uses a four-point strap-type tiedown system, each strap assembly must be clearly and permanently marked to note its intended position, such as "right-rear tiedown" or simply "rear tiedown" as is important to the performance of the particular system.

Finally, the WTORS needs to be clearly marked to indicate that it is in compliance with J2249, and that it complies with the dynamic strength test performance requirements of 6.2. In general, it is expected that this label will include a statement that the WTORS has been impact tested using the 85-kg surrogate wheelchair and 76.3 kg ATD. However, for WTORS tested with a particular commercial wheelchair for which it has been specifically designed, the labeling must clearly indicated the make, model, name, and mass of the wheelchair and ATD for which the WTORS has been tested and

is to be exclusively used. This information must also be included in the manufacturer's presale literature to warn the potential purchaser that the WTORS has been designed for use with a specific wheelchair and that it has limited application.

5.2 Instructions for Installation

- The requirements in J2249 for instructions to WTORS installers are as follows. Manufacturers of WTORS shall provide written instructions for the installer that include:
- a) diagrams showing acceptable methods for fastening WTORS anchorage's to the vehicle,
 - b) a description of how the WTORS is to be used so that the installer may be fully informed regarding the purpose and function of all components and how they should be installed,
 - c) a statement that if a head restraint is anchored to the vehicle, a vehicle-anchored back restraint must be provided to minimize rearward deflection of the wheelchair seatback and thereby prevent neck injury,
 - d) an exploded-view drawing, parts list, or receiving inspection checklist for all components required in the installation,
 - e) if fasteners are not supplied as part of the WTORS assembly, the minimum specifications for all wheelchair tiedown and occupant restraint anchorage fasteners and related components. The specifications shall be based on the material, size, and quantity of anchorage fasteners used in the simulated frontal impact test of Appendix A,
 - f) a statement that vehicle anchor points may require reinforcement, along with a minimum strength recommendation for the vehicle at all WTORS anchor points,
 - g) identification of any components to be permanently fastened to the wheelchair and a description of procedures for attachment,
 - h) a statement of the number of separate packages containing WTORS components,
 - i) a description of the types of anchorage fittings that are suitable for use with the vehicle-installed anchorage's,
 - j) recommended distances between anchor points of four-point wheelchair tiedowns, along with Figures 5 and 6,
 - k) recommended locations, relative to wheelchair tiedown anchor points, for anchor points of pelvic restraints that are intended to anchor directly to the floor of the vehicle, and an explanation that pelvic-restraint anchor points should be selected to achieve side-view projected restraint angles of 30 degrees or greater, and preferably between 45 and 75 degrees, to the horizontal, as shown in Figure 7, in order to reduce the possibility of the pelvic restraint loading the occupant's abdomen,

- l) recommended locations for upper anchor or upper guide support points of shoulder and harness restraints, and an explanation that these points should be positioned so that the belt webbing passes over the midpoint of the occupant's shoulder and at a height that is at or above the level of occupant's shoulders so as not to impose downward loads on the spine,
- Note: See tables and figures in Appendix F for more information on torso belt fit.
- m) a diagram indicating recommended distances between WTORS anchor points and vehicle interior components along with the illustration of Figure 8, indicating that the distances are based upon the desire to maintain clear zones for potential head excursions of occupants provided with both upper and lower torso restraint, or with only a pelvic restraint, as applicable to the particular transportation situation,
 - n) an instruction that, to reduce the possibility of head injury to wheelchair-seated passengers, vehicle components that are inside of the clear zones of Figure 8 should comply with the impact performance requirements of FMVSS 201,
 - o) an instruction that all vehicle padding should comply with FMVSS 302, Flammability of Interior Materials,
 - p) a statement that an airbag shall be used only as a supplementary occupant restraint in combination with a wheelchair tiedown and belt-type occupant restraint system that complies with the requirements of this recommended practice, and
 - q) a statement that airbags should be disconnected if the wheelchair-seated occupant is positioned less than 175 mm from the airbag module, or if any after-market device is installed so as to block or compromise deployment of the airbag.

A well designed WTORS system will not provide effective protection if it is not installed properly. This section of J2249 specifies the *minimum* requirements for written instructions that the WTORS manufacturer must provide to properly and effectively install the system in a vehicle. One of the primary issues addressed is the locations of anchor points to achieve effective performance of the particular type of wheelchair tiedown. For example, for a four-point, strap-type tiedown, the WTORS manufacturer is required to indicate that the system should be installed to achieve angles of rear tiedown straps of 30 to 45 degrees to the horizontal in order to resist both forward and upward movement of the wheelchair during a frontal impact. In many instances, the installer does not have control over these angles, which are dependent on the locations of tiedown or securement points on the wheelchairs, and also on the relative positioning of the wheelchair within that space. However, J2249 requires that the WTORS manufacturer provide this information so that the installer will be knowledgeable of the goals of a good installation and can therefore install the system for optimal performance.

Similarly, the manufacturer must provide installation recommendations for pelvic and shoulder belts (k and l, respectively) in order to achieve a good fit to potential users. For the pelvic belt, the goal is to set the anchor points to achieve a belt angle between 30 and 75 degrees to the horizontal during normal use, and preferably above 45 degrees. Although this may not be realizable for all wheelchair users at a particular station in a public or school transportation vehicle, the information is provided so that the

installer knows the objects of the installation - i.e., to achieve steeper angles rather than shallow angles, since low angles increase the probability of the pelvic bone submarining under the lap-belt webbing and the belt loading and lacerating the abdominal organs, which can lead to serious and fatal injuries.

Several of the requirements in 5.2 require that the WTORS manufacturer instruct the installer as to proper hardware installation techniques, including diagrams (5.2.a), specifications for fasteners (5.2.e), and the need to provide additional reinforcement for some anchor points, such as installation into sheet metal. At one time, the information in F.1.3 and F.1.4 of Appendix F (i.e., recommendation for installing anchorages into structural members and for use of backing plates when installing into sheetmetal) was included in the requirements of 5.2, but these were replaced by the more general statements in Section 5.2, which places the responsibility for the details about effective installation on the WTORS manufacturer.

A WTORS system is only as strong as its weakest link and, if fasteners are not of required hardness, size, or quantity, an otherwise effective WTORS may catastrophically fail when needed in a crash. In this regard, there was considerable discussion during the development of the standard about whether the WTORS manufacturer should be required to provide all fasteners for anchorages with the WTORS. Some manufacturers agreed that this was essential, while others thought that it was inappropriate and unnecessarily costly because the length of the fasteners needed depends on the type of installation and vehicle, making it necessary to include fasteners of different dimensions to cover all possible installation scenarios. The final requirement is that the manufacturer either include the fasteners, or include the minimum specifications for the fasteners, based on the fasteners used in the dynamic test of Appendix A. While not specifically required by J2249, it is recommended that WTORS manufacturers include specifications for fasteners, even when the fasteners are provided with the WTORS, in the event that substitution or replacement is needed.

Clause (c) of this section is a warning to installers who might think it is beneficial to install a vehicle-anchored head restraint to limit rearward head movement and neck bending in rear impacts or on rebound from frontal impacts. The statement tells installers that, if they do this, they must also install an effective vehicle-anchored back support. The reason is that most wheelchair backrests will deform under occupant loading from a rear impact, or during occupant rebound from a frontal impact. If this occurs, but the head is effectively restrained by a vehicle-anchored headrest, serious injury to the neck can occur. It is better for the head and torso to move backward together, perhaps with a head restraint attached to the wheelchair seatback, assuming that the wheelchair backrest deflects rearward but does not totally collapse.

Clauses (b), (d), (g), and (h) address the packaging and identification of the pieces and parts that comprise the WTORS and are self explanatory. Clause (i) requires that the WTORS manufacturer tell the installer about the types of anchorages that will work effectively with the installed anchorages. For example, different types of anchorage track are used with four-point, strap-type tiedowns, and it is important that the installer, as well as the users, understand the types of end fittings that will effectively engage with the particular type of track included in the WTORS kit. Small differences in dimensions or design features between anchorage track from different manufacturers may result in ineffective engagement and performance.

The remaining requirements of this section deal with instructions that address the concern of occupants contacting vehicle components in an impact situation, and concerns about the use of airbags with wheelchair seated occupants. On the first issue, the standard requires that the WTORS manufacturer indicate the need for clear space, both in words and by illustration (Figure 8 of the standard), and the need to place effective, non-flammable padding on vehicle components that may fall within the needed clear space. By "effective" is meant padding that absorbs energy and reduces head accelerations when dynamically tested as specified in FMVSS 201. An example of material that would comply with FMVSS 201 is 19-to-25 mm thick Rubatex R 3901-SV (Rubatex is located in Bedford, Virginia; phone: 1-800 RUBATEX).

With regard to airbags, J2249 requires that the installer be warned by the WTORS manufacturer not to use airbags without an effective belt restraint system (i.e., that airbags are supplementary restraints), and that the installer should call the vehicle manufacturer and/or the National Highway Traffic Safety Administration (NHTSA) if they suspect that an occupant may sit too close to the airbag module, which can result in serious or fatal injury from the energy of the airbag deployment. Just prior to publication, this latter provision specified "too close" as when any part of the wheelchair occupant's body was within 175 mm (about 7 in) of the airbag module. This distance, however, was removed since some WTORS manufacturers may choose to be more conservative (i.e., instruct to disable the airbag if people sit within 200 mm of the module), and since airbag systems may change so as to make a smaller distance acceptable in the future. It should also be noted that, at the time of this publication, the NHTSA was using 250 mm (10 in) as the minimum recommended distance between the airbag module and the occupants during normal vehicle operation.

5.3 Advice and Warnings for Installers

This section of Part 5 contains additional requirements for special "advice" and "warnings" to installers that the manufacturer *must* provide. They are separated from the written requirements of 5.2 to make the point that these statements should be more strongly "flagged" in the installer instructions (e.g., larger, bold, all caps font), although no requirements about font size and type are specified. The requirements are that a

WTORS manufacturer warn the installer by providing:

- a) a statement that the WTORS complies with all applicable requirements of SAE J2249, including a 48-kph, 20-g frontal impact test using either:
 - i) a forward-facing surrogate wheelchair with a mass of 85 kg and an ATD with a mass of 76.3 kg, or
 - ii) a specific production wheelchair and an appropriate size ATD, along with the mass of the test wheelchair and ATD.
- b) a statement that the WTORS should only be installed for forward-facing seating,
- c) advice to have the WTORS installed by an experienced technician,
- d) descriptions of any wheelchair features that are required to allow correct fitting of WTORS components that are to be permanently fastened to the wheelchair,
- e) a general warning to consult the WTORS manufacturer in case of questions as to the method of installation on the wheelchair and/or in the vehicle,
- f) a warning that anchorages should not be installed into unsound materials such as corroded metal, wood, plastic, and fiberglass panels, without additional and suitable reinforcement,
- g) a warning against making alterations or substitutions to the WTORS parts or components without consulting the WTORS manufacturer,
- h) a warning that the equipment has been tested in a configuration similar to that recommended by the manufacturer and that any deviation from the manufacturer's recommendations is the responsibility of the installer, and
- i) a warning to protect webbing from contacting sharp corners and edges

The first requirement is that the manufacturer indicate compliance with SAE J2249 and mention the 48 km/h (30 mph), 20-g dynamic test. In most cases, the manufacturer will have tested with the 85-kg surrogate wheelchair and 76.3 kg adult test device (ATD) and will so indicate, thereby making a statement that the WTORS is suitable for use with essentially all wheelchairs (i.e., wheelchairs of relatively high mass). However, since the standard allows for a WTORS to be tested with a specific wheelchair that may have a lower mass, 5.3.1(b) requires that the WTORS manufacturer indicate the specific type of wheelchair and mass of wheelchair occupants (i.e., as represented by the anthropomorphic test device) for which it was designed and tested.

It is perhaps worth noting again that the main part of the comparable ISO standard (i.e., ISO 10542-1) only allows testing with the 85-kg surrogate wheelchair and 76.3 kg ATD, so that compliance with Part 1 makes a singular statement about the dynamic strength of WTORS that comply. Testing of WTORS designed for use with only a specific, and potentially lower mass wheelchair will be accomplished in a separate part of the ISO

standard that provides for testing a combination of commercial wheelchairs and commercial WTORS (Part 5) and that is still under development at this time. It is still not clear, however, how this separation of testing with lower mass wheelchairs into a separate part of ISO 10542 will accomplish the desired goal, since the distinction between tiedowns tested with the 85-kg surrogate wheelchair and lower mass wheelchair must still be accomplished by labeling on the WTORS equipment.

Clause (b) is a warning to use the WTORS only in the forward-facing mode, and is self explanatory but extremely important, since it is, and has been, common practice to place wheelchairs and their occupants facing toward the aisle of the vehicle (i.e., sideways). This is essentially a restatement of part of the Scope of J2249 which says that J2259 only applies to WTORS designed for use with forward-facing wheelchairs and occupants.

During development of the recommended practice and the comparable ISO 10542, there was considerable discussion over the requirement for the warning in (c) that a WTORS be installed by an "experienced technician." The concern was that there is no objective criteria about what constitutes an experienced technician. Nevertheless, the requirement for this warning was retained in J2249, with the understanding that it does convey a message about using knowledgeable people to install this equipment, while leaving the judgment of what constitutes an experienced technician up to the installer.

5.4 User Instructions

This section requires that a WTORS manufacturer provide the consumer or user of the WTORS (i.e., the person in the wheelchair or the persons responsible for transport of the person in a wheelchair) information about the proper use and maintenance of the wheelchair tiedown and the occupant restraint. These instructions must be provide on a durable instruction sheet that can kept and displayed in the vehicle, and many are similar to the instructions provided to the installer. This instruction sHEET shall include:

- a) a statement that the WTORS complies with all applicable requirements of SAE J2249, including a frontal impact test conducted at 48 kph, 20 g using:
 - 1) a forward-facing surrogate wheelchair with a mass of 85 kg and an ATD with a mass of 76.3 kg, or
 - 2) a specific production wheelchair and an appropriate size ATD, along with the mass of the test wheelchair and ATD.
- b) a statement that the WTORS has been dynamically tested with an anthropomorphic test dummy restrained by both pelvic and upper-torso restraints, and that use of only a pelvic restraint may compromise the performance of the WTORS,
- c) for WTORS designed to transfer loads through the wheelchair, a statement indicating this, along with a description of the specific wheelchair for which the WTORS has been designed and impact tested,
- d) a statement that the WTORS is to be used only with forward-facing wheelchairs,

- e) a description of the types of anchorage hardware that may be used with the vehicle-installed anchorage components,
- f) a description of the features required of a wheelchair for the WTORS securement hardware to effectively attach to it,
- g) a description of the correct positioning of the occupant restraint on the user, including:
 - 1) a statement that the pelvic restraint is designed to bear upon the bony structure of the body and should be worn low across the front of the pelvis with any junctions between the pelvic and shoulder restraints located near the wearer's hip,
 - 2) a statement that the angle of the pelvic restraint should be within the preferred zone of 45 to 75 degrees to the horizontal, or the optional zone of 30 to 45 degrees to the horizontal, as shown in Figure 7,
 - 3) a statement that restraints should not be held away from the body by wheelchair components or parts, such as the wheelchair armrests or wheels, along with the illustration of Figure 8,
 - 4) a statement that occupant restraints should be adjusted as firmly as possible and consistent with user comfort,
 - 5) a statement that upper torso restraints should fit over the shoulder or shoulders, and
 - 6) a statement that restraint webbing should not be worn twisted,
- h) a statement that the WTORS should be used as shown in the manufacturer's instructions,
- i) a statement that all WTORS webbing and components should be inspected, cleaned, and maintained regularly and:
 - 1) that care should be taken to prevent contamination of the webbing with polishes, oils, and chemicals, particularly battery acid,
 - 2) procedures for cleaning webbing,
 - 3) that frayed, contaminated, or damaged webbing should be replaced,
 - 4) that broken and worn parts should be replaced, and
 - 5) that WTORS components, including anchorages, that are suspected to have been in use during an impact from which the vehicle must be towed should be replaced,
- j) a statement that auxiliary wheelchair equipment should be effectively secured to the wheelchair or removed from the wheelchair and secured in the vehicle during transport so as not to break free and cause injury to vehicle occupants in an impact, and
- k) a statement that, whenever possible, items attached to the wheelchair in front of the occupant should be removed and secured separately during transportation to prevent potential injury to the wheelchair occupant.

Since J2249 allows for testing with either the 85-kg surrogate wheelchair and associated 76.3 kg ATD, as well as with a specific wheelchair and the appropriate size ATD that may be of lower mass, the user (as well as the installer) must be informed, as required by (a), of the sizes and masses of wheelchair and dummy used in the dynamic test, since this may have significant implications on its range and limits of application. Note, however, that the mass of the ATD and the mass of the surrogate wheelchair do not, and need not, correspond to the limits of wheelchair and occupant mass in real-world use. The user is also to be instructed (clause d) that the WTORS is intended only for use with forward-facing wheelchairs and occupants, and is to be strongly encouraged in the user instructions to use both the lower and upper torso belt restraints (clause b).

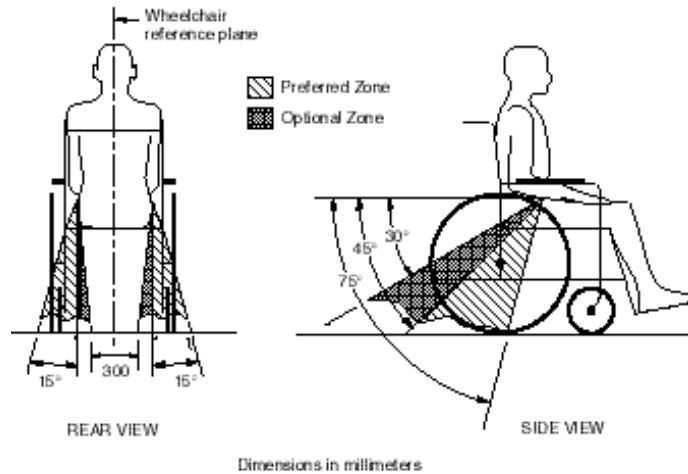

Figure 7 – Preferred and optional angles for pelvic belts.



Figure 8 - Restraints should not be held away from the body by wheelchair components or parts, such as the wheelchair armrests or wheels.

Although WTORS with four-point, strap-type tiedowns are required to have end fittings that engage with the securement points on the surrogate wheelchair (Figure E4), there are no requirement for attachment hardware of other types of tiedowns at this time. Therefore, the user is to be informed (f) of the wheelchair features (i.e., geometry) required for effective attachment of the tiedown system, both for end fittings that attach temporarily when the wheelchair is in a vehicle, as well as for add-on attachment components that are permanently fastened to the wheelchair.

Similarly, since anchorage end fittings may be disconnected from anchorage hardware fastened to the vehicle and potentially used in other vehicles (e.g., Kinedyne anchorage hardware attached to the strap assembly can be removed from the aluminum tiedown track), the user must be informed (clause e) of the specific type of anchorage hardware that can effectively be engaged with the anchorage components installed in

the vehicle, and visa versa. For example, there are numerous types of aluminum and steel tiedown track that bolt to the floor of the vehicle. However, as indicated previously, there may be small differences in the dimensions of the anchorage track that determine the types and sizes of anchorage components needed for effective performance under impact loading. It is therefore important that the WTORS manufacturer provide information in sufficient detail about key factors that are necessary to ensure proper use of the different separable components of the WTORS, in the event that they become separated or sold separately (see 5.5 below).

Since J2249 allows for WTORS with an occupant restraint that anchors to the wheelchair, and thereby transfers occupant restraint loads directly to the wheelchair (i.e., by dynamically testing with the actual wheelchair), the manufacturer is required in clause (c) to make this limitation clear in the user instructions whenever applicable, and to provide a description of the wheelchair or wheelchairs for which it has been designed and tested. It is hoped, of course, that most wheelchairs will eventually be designed and tested with on-board occupant restraints (i.e., through compliance with ANSI/RESNA WC/19), so that such a statement to the user will not be necessary, but this will not be possible for several years.

Item (g) of this part of J2249 requires the manufacturer to provide information to the user, similar to that provided to the installer in 5.2, on the proper wearing and fit of belt-type occupant restraints to maximize their effectiveness in reducing injuries. In particular, Figure 7 is used to indicate preferred and optional angles for the pelvic belt. Item (i) requires the manufacturer to inform the user about procedures for maintenance and possible replacement of worn or dynamically loaded WTORS. The latter is important since, even if there are no obvious signs of failure, a system may be weakened or, in the case of seat-belt webbing, stiffened, after it is loaded in an impact, thereby changing its potential effectiveness and energy-absorbing properties, should the vehicle be involved in another impact situation.

Finally, items (j) and (k) require that the user be warned about potential problems with auxiliary equipment that may be attached to the wheelchair to serve the needs of the user. Such items can break loose and cause injury to other occupants and should therefore be effectively secured to the wheelchair or detached and stored elsewhere in vehicle. Items placed in front of the wheelchair occupant, such as trays, often have fairly rigid and narrow edges, and the user must be informed of the potential hazard (k) such items can present in a crash environment. Although this is not strictly the WTORS manufacturer's responsibility, since it is not part of the WTORS system, such items can reduce the ability of the WTORS to provide effective occupant protection. Therefore, it was decided that the WTORS manufacturer must at least bring this concern to the user's attention. In many cases, removing items such as trays may not be an acceptable option. In these cases, placing energy-absorbing padding between the

tray and the wheelchair occupant, and/or increasing the space between the occupant and the tray, is recommended.

5.5 Instructions for WTORS Components and Subassemblies Sold Separately

- 5.5.1 Parts and subassemblies of WTORS that are not supplied as parts of complete kits shall be supplied with installation, user, and maintenance instructions that include details of the WTORS devices and components with which they are compatible.
- 5.5.2 A replacement part for WTORS shall include appropriate installation instructions for that part.

Not too many years ago, it was often the case that a wheelchair-seated occupant was provided with some kind of wheelchair tiedown, or some kind of occupant restraint, but not both. For this reason, one of the goals of J2249 is to encourage the marketing and use of complete WTORS systems that include both an effective wheelchair tiedown and a properly designed occupant restraint. However, it was recognized during the development of J2249 that some manufacturers market pieces and components of WTORS that are assembled into a complete system by a third party. An example is the anchorage track sold by Kinedyne, Inc. that is used in WTORS with four-point tiedowns marketed by several different companies.

Thus, while J2249 applies primarily to the companies that assemble and market the final WTORS, this section was included to address the situations where WTORS components and parts are marketed separately, to insure that these parts are in compliance with J2249. Such parts must, of course, be tested to J2249 as part of a complete WTORS, and must be marketed with appropriate documentation required by 5.1 through 5.4, as is appropriate to the particular component. Similarly, 5.5.2 allows all manufacturers to market replacement parts for complete WTORS that are in compliance with J2249, but stipulates that such replacement parts include "appropriate" installation instructions.

6. Performance Requirements

While Section 4 of J2249 contains requirements that address the design intent of the WTORS manufacturer, Section 6 specifies *minimum* performance requirements for WTORS. Except for the first subsection (i.e., 6.1) which requires adherence to selected parts of existing federal motor vehicle safety standards for belt restraint design and materials, specific test methods to determine compliance are provided in Appendices to J2249 as follows:

- Appendix A - Frontal Impact Test (i.e., dynamic test)
- Appendix C - Test for Partial Engagement of WTORS Components

- Appendix D - Test for Webbing Slippage at Tiedown Adjustment Devices of

Wheelchair Tiedown Straps

6.1 WTORS Components

This subsection of performance requirements references applicable parts of FMVSS 209, *Seat Belt Assemblies*, and FMVSS 302, *Flammability of Interior Materials*. While FMVSS 209 applies strictly to belt restraint systems, several parts were also considered applicable to webbing, metal parts, and mechanisms of tiedown assemblies, as noted in the last column of Table 2 reproduced below.

**Table 2 of J2249
Applicable Subsections of FMVSS 209**

Section	Component	Subject	Tests referenced	Application*
S4.1 (a)	general design	occupancy	-	R
S4.1 (b)	pelvic restraint	design	-	R
S4.1 (c)	upper torso restraint	design	-	R
S4.1 (d)	hardware	burrs & sharp edges	-	R + TD
S4.1 (e)	release mechanism	design	-	R
S4.1 (g)	restraint assemblies	adjustment range	-	R
S4.1 (h)	webbing	unraveling	-	R + TD
S4.2 (a)	webbing	belt width	S5.1(a)	R
S4.2 (b)	webbing	breaking strength	S5.1(b)	R + TD
S4.2 (c)	webbing	elongation	S5.1(c)	R + TD
S4.2 (d)	webbing	abrasion resistance	S5.1(d), S5.3(c)	R
S4.2 (d)	webbing	abrasion resistance	S5.1(d)	TD
S4.2 (e)	webbing	light resistance	S5.1(e)	R + TD
S4.2 (f)	webbing	microorganism resistance	S5.1(f)	R + TD
S4.2 (h)	webbing	stain resistance	S5.1(h)	R + TD
S4.3 (a)	hardware	corrosion resistance	S5.2(a)	R + TD
S4.3 (b)	hardware	temperature resistance	S5.2(b)	R + TD
S4.3 (d)	buckle release	release force	S5.2(d)	R
S4.3 (e)	adjustment device	adjustment force	S5.2(e)	R
S4.3 (f)	tilt-lock devices	locking angles	S5.2(f)	R
S4.3 (g)	buckle latch	separation force	S5.2(g)	R
S4.3 (h)	belt retractor	performance	S5.2(h)	R
S4.3 (i)	belt retractor	performance	S5.2(i)	R
S4.3 (j)	belt retractor	performance	S5.2(j)	R
S4.3 (k)	belt retractor	performance	S5.2(k), S4.4	R
S4.4 (a)	pelvic restraints	performance	S5.3(a)	R
S4.4 (b)	3-pt restraints	performance	S5.3(b)	R

* R = occupant restraint; TD = wheelchair tieddown.

6.2 Frontal Sled Impact Test

This subsection of performance requirements sets forth the criteria for passing the frontal-impact dynamic strength test of WTORS. This is the test that assesses the potential for a WTORS to provide effective wheelchair securement and effective occupant restraint to the wheelchair user in a frontal crash test. These criteria are fundamental to J2249 and require that the WTORS:

- a) retain the ATD in the test wheelchair and on the test sled with the test wheelchair in an upright position,
- b) not show any visible signs of tearing, fragmentation, fracture, or complete failure of any load carrying part, unless that part is designed to tear or fail in a controlled and predictable manner to limit forces on the occupant,
- c) not become detached or separated at anchorages or securement points,
- d) not allow the horizontal excursions of the test dummy and the test wheelchair to exceed the values given in Table 3 (see below),
- e) prevent the wheelchair from imposing forward loads on the occupant as indicated by:

$$X_{knee}/X_{wc} \geq 1.1$$

- f) allow removal of the ATD and the test wheelchair subsequent to the test without the use of tools.

Measurement Point	Excursion Variable	Pelvic & Shoulder Restraint
Test Wheelchair	X_{wc}	200
ATD Knee	X_{knee}	375
ATD Head	X_{head}	650

where,

X_{wc} = the horizontal distance relative to the sled platform between the contrast target placed at or near point P on the test wheelchair at time t_0 , to the point P target at the time of peak wheelchair excursion.

X_{knee} = the horizontal distance relative to the sled platform between the dummy knee-joint target at time t_0 , to the knee joint target at the time of peak knee excursion, and

X_{head} = the horizontal distance relative to the sled platform between the most forward point on the dummy's head above the nose at time t_0 , to the most forward point on the dummy's head at the time of peak head excursion,

The peak ATD and wheelchair forward excursion limits in Table 3 are based on measurements of typical excursions in “successful” tests of WTORS at the time J2249 was written. As improvements in WTORS are achieved, and as more test results with the surrogate wheelchair become available, it is expected that these excursion limits may be decreased in future versions of Recommended Practice.

6.3 Partial Engagement of Anchorage and Securement Components

The performance requirement of this subsection applies to anchorage and securement components of both tiedowns and occupant restraints, and it applies to components of all types of tiedowns, including docking and strap assemblies. The test procedures of Appendix C require that all hardware components that may be manually separated, such as tiedown anchorages of strap assemblies that plug into anchorage track on the vehicle, or components of a docking system attached to the wheelchair that engage with docking hardware anchored to the vehicle, be connected in all possible and foreseeable ways, other than the intended manner for effective lockdown. For each such connection, a force is applied to separate the parts. If the separation force is greater than 22 N (about 5 lb), it is assumed that proper engagement may be erroneously perceived, and the WTORS fails the test. That is, for each improper engagement, components must separate easily so as **not** to give the impression of proper and effective engagement.

6.4 Webbing Slippage at Tiedown Adjustment Devices

When tested as specified in Appendix D, webbing adjustment mechanisms of the wheelchair tiedown system shall not show slippage greater than 25 mm.

7. Test Report

Although this section is titled *Test Report*, its primary purpose is to itemize the documentation that a WTORS manufacturer shall have on file as evidence that the particular WTORS complies with SAE J2249 and is therefore justified in being so labeled. Much of this information would of course be provided in the test report by the test lab that performs the tests. However, many of the tests may be performed by the WTORS manufacturer. The section is essentially a recap of the design and performance requirements set forth in the body of the standard.

V. Guidelines for Users of WTORS

The following guidelines are intended as a reference by users and prescribers of wheelchairs, as well as for attendants and operators who are responsible for the appropriate use of securement and restraint devices in motor vehicles used to transport wheelchairs. The guidelines are based on existing US laws and regulations, as well as on the biomechanical principles outlined in Section III above. In addition, experiences gained over the past 20 years in wheelchair and securement device crash testing under laboratory conditions has yielded valuable performance information regarding actual products in the marketplace. Finally, the preparation of both national and international standards, as referenced in Appendix A, has created excellent opportunities for information sharing of experiences on a world wide scale. Many of these sharing experiences have also influenced the following guidelines (part 3).

1) *The key provisions in existing US laws*a) Transit vehicles (ADA)

- all " common " wheelchairs shall be transported
- clear floor space of at least " 30"x48" for at least two forward-facing wheelchair stations must be provided near vehicle entrance
- transit entity may require use of securement devices
- access cannot be denied on basis of an unsecureable wheelchair
- transit entity may request transfer to regular seat, but can not require it
- tiedowns and occupant restraints shall be provided for each wheelchair station
- use of occupant restraints optional
- securement devices must meet a stated minimum static strength requirement
- movement of wheelchair must not exceed 2" during normal driving

b) School buses (FMVSS-222)

- wheelchairs must be forward facing
- both wheelchair securement and occupant restraint devices must be provided
- each wheelchair station must have at least four securement anchorage's
- each tiedown anchorage must meet a stated minimum static strength requirement
- each restraint anchorage must meet a stated minimum static strength requirement.
- securement straps must have a means for minimizing slack

c) Private vehicles

The provisions of several Federal Motor Vehicle Safety Standards that apply to manufacturers of passenger vehicles have been used as a basis for many of the provisions of SAE j2249. These include:

- FMVSS 208 – Occupant Crash Protection
- FMVSS 209 – Seat Belt Assemblies
- FMVSS 210 - Seat Belt Assembly Anchorages
- FMVSS 213 – Child Restraint Systems Seat Belt Assemblies and Anchorages

2) The key provisions (requirements) for products to conform to US voluntary industry standards and recommended practice

a) Wheelchair securement products (J2249)

- designed for use by forward-facing children and adult wheelchair occupants
- not depend on the wheelchair brakes to conform with this recommended practice
- designed for use in both private and public vehicles
- capable of withstanding a 20g, 30 mph simulated frontal crash
- end fittings compatible with transit wheelchairs that conform to ANSI/RESNA, WC-19⁸
- function without any component of the tiedown passing through the wheels of the wheelchair
- allow for routine release of the wheelchair within 60 seconds without the use of special tools
- designed to prevent unintentional loosening of any threaded fasteners
- include a manual override for any power operated systems in the event of a power failure
- designed to eliminate free movement without the use of tools
- allow for the adjustments of tiedown strap lengths without the use of tools
- have specified labelling and identification
- be marketed with specified presale information, installation guidelines and user instructions.

b) Occupant restraint products (J2249)

- designed to be used by both passengers and drivers
- include both pelvic and upper torso restraints
- lengths be manually adjustable to accommodate a wide range of body sizes without the use of tools
- not depend on an airbag to conform to this recommended practice

⁸ see Appendix A

- be marketed with specified labeling, permanent identification markings, installation guidelines and user instructions.

c) Transit wheelchairs (ANSI/RESNA, WC/19)⁹

- designed to be secured as a forward-facing seat for use in both public and private motor vehicles
- four clearly identified securement points (2 front, 2 rear) that will accept tiedown end fittings that conform to J2249
- permit a vehicle-anchored pelvic restraint to cross the pelvis to anchor points within the specified 30-75° angle range
- provide a clear path for fastening pelvic restraint straps to anchor points on the tiedown or vehicle floor
- if wheelchair anchored, provide a pelvic restraint angle within the specified range of 30-75°.
- if postural supports are provided, they be designed to break away at low forces or comply with J2249
- meet the requirements of the specified 30mph/20 g sled impact
- be marketed with specified presale information, installation guidelines and user instructions
- have specified labelling and permanent markings .

3) What can be considered "best practice" today?

The following are recommendations that are possible with today's technology, however they may not be feasible in every case due to the existence of products that were marketed prior to the formal issuance of the above standards and recommended practice guidelines.

a) General Principles

It must be recognized that wheelchair-occupant protection while seated on a moving motor vehicle is a systems issue. That is, effective occupant protection can only occur when the wheelchair, the wheelchair securement, the occupant restraint and the vehicle are viewed as a complete protection system. The effectiveness of the system will only be as good as the weakest component in the system. For example, if a wheelchair passenger is secured in a motor vehicle meeting all the ADA and FMVSS requirements, but the attachment location to the wheelchair, or the wheelchair itself does not meet specifications, this creates a system deficiency that, although certainly better than no securement, is less than adequate given what is possible using today's knowledge and technology. Again, sometimes these "best practice" arrangements are unachievable due to technical, financial or other constraints. However, when selecting new products, wheelchair users and prescribers should include these transport safety principles in their decision-making process. Given the passage of the related federal laws and regulations, combined with the increasing adoption of voluntary industry standards, new opportunities are

⁹ see Appendix A for status information

rapidly emerging to make product selections that can vastly improve the transport safety of wheelchair users.

Standards are always a moving target, In fact, all standards setting organizations mandate a review and if necessary, revision every five years. Therefore, it is essential for those seeking current information that they make sure that they have access to the most current versions.

Wheelchair occupants in motor vehicles are generally not the only passengers needing occupant protection. Therefore, J2249 and its other related standards, have attempted to maintain the safety of others passengers while introducing the requirements specific to the wheelchair and its occupant.

Four-point strap-type securement devices are by far the most commonly used securement technology in North America. For this reason, the evolving industry standards and the Federal regulations are to a large extent based on these technologies. This is also the case for these guidelines and the following recommendations.

In addition, the following " best practices" recommendations are extractions from the principles and standards discussed above that are particularly pertinent to wheelchair users, prescribers and those that assist directly with the transport of persons using wheelchairs.

b) Wheelchair selection for transit use

When selecting a wheelchair that is also intended for use as a seat in a motor vehicle, the following principles or features should be fully considered:

- very few wheelchairs, as of 1/98, have designed for use as a seat in a motor vehicle
- the availability of structurally adequate securement points (2 front, 2 rear) that are compatible with tiedown end fittings specified in J2249
- the presence of rigid components in the occupant compartment that could present injurious contact areas in the event of a crash
- unobstructed pathways that will allow for vehicle-anchored restraints straps to pass closely across the body at the appropriate anatomical locations, and most preferably
- evidence, through permanent labeling or presale literature, that the wheelchair has been tested to ANSI/RESNA, WC-19 or a comparable standard¹⁰.

c) Wheelchair securement

- most commercially available strap-type securement devices have been tested to J2249 and should be advertised accordingly.

¹⁰ see Appendix A--Wheelchairs

- insist on transporters using a forward facing wheelchair orientation in the vehicle.
- assuming a four point strap tiedown system, use all four straps to secure the wheelchair.
- assuming no designated securement points, attach tiedowns only on structural members and as close to the center of gravity (CG) of the W/C as possible. A good estimate of the vertical location of the CG for most wheelchairs is in a zone ranging from 9-12" above the floor.
- assuming they are available, use only the four designated wheelchair securement points, and
- take time to remove the slack using the adjustable mechanisms on the tiedown straps.

d) Occupant restraint

- use both the pelvic and shoulder belts.
- locate the pelvic restraint low over the bony structures of the pelvis (range 45-75° angle from horizontal (see figure 5)).
- if adjustable, locate the upper trunk restraint belt anchor point so that the belt crosses the chest at the mid clavicle (collar bone) region (approximate angle-55° to horizontal).
- distribute restraint forces to as large an area as possible, but avoid soft tissue areas such as the abdomen and neck.
- do not confuse the use of postural belts with occupant restraint belts. If necessary, the former should be labeled as inadequate for such use unless it conforms to the strength requirements of J2249, and
- during application insure a snug fit of occupant restraints by removing unnecessary belt slack, as is comfortably possible.

VI. Guidelines for WTORS Transportation Authorities and Installers

The information contained within this section of the Companion Document is intended to guide transportation authorities and WTORS installers. A well designed WTORS is ineffective unless it is properly installed. Accordingly, installers of WTORS must be accomplished using experienced technicians only. Installers are urged to consult complete installation instructions accompanying purchased WTORS, and supplemental information contained in the SAE J2249 document. Several of the key provisions are highlighted below.

- _A complete WTORS consisting of a minimum of four tiedowns, a pelvic restraint and a shoulder restraint must be provided at each wheelchair securement station.
- _Inspect WTORS to verify that WTORS are labeled indicating compliance with SAE J2249.
- _WTORS should be installed for use only with forward-facing wheelchairs.
- _Do not in any way alter the WTORS components, as their crash integrity may be compromised.
- _Do not substitute WTORS parts or components unless, approved by the WTORS manufacturers.
- _Verify that complete manufacturer's installation instructions are contained within the packaging.

Instructions should include:

- _diagrams and methods for fastening WTORS anchorages to the vehicle, along with a description of the types of anchorage fittings that are suitable for use with the vehicle-installed anchorages,
- _a description of how the WTORS is to be used as well as the purpose and function of all components,
- _a drawing, parts list, or receiving inspection checklist for all components required in the installation,
- _ if fasteners are not supplied as part of the WTORS assembly, the minimum specifications for all wheelchair tiedown and occupant restraint anchorage fasteners and related components. The specifications shall be based on the material, size, and quantity of anchorage fasteners used in the simulated frontal impact test,
- _recommended distances between anchor points of four-point wheelchair tiedowns. The figures below provide recommended tiedown angles.
- _recommended locations, relative to wheelchair tiedown anchor points, for anchor points of pelvic restraints that are intended to anchor directly to the floor of the vehicle, and an explanation that pelvic-restraint anchor points should be selected to achieve side-view projected restraint angles of 30 degrees or greater, and preferably between 45 and 75 degrees, to the horizontal, as shown in figure

below, to reduce the possibility of the pelvic restraint loading the occupant's abdomen,

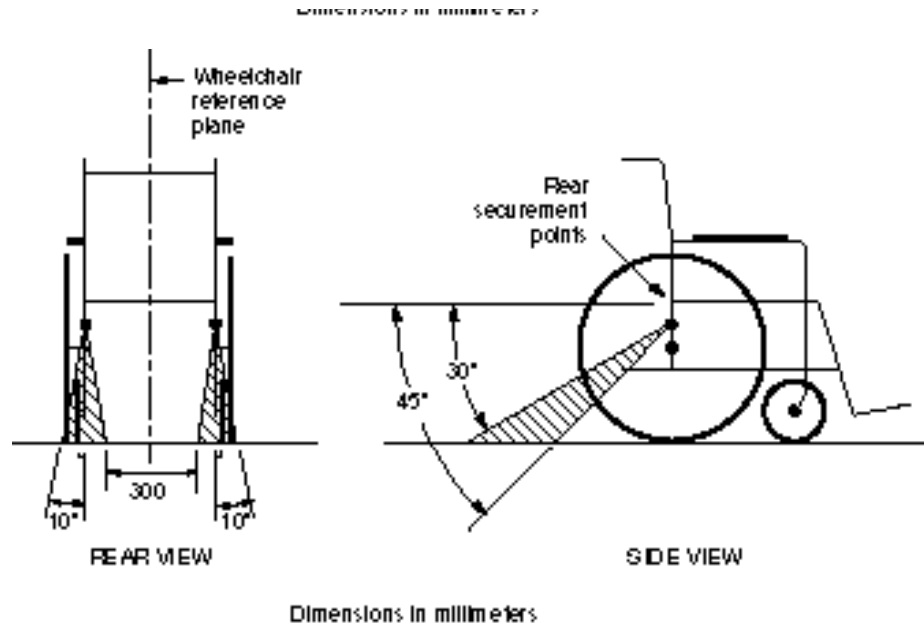

Figure 9-Preferred angles and locations of rear wheelchair tiedown straps and vehicle anchor points. Note that angles indicated are obtained by projecting the angle of each tiedown strap onto a vertical plane parallel to the wheelchair reference plane (side view) or onto a vertical plane that is perpendicular to the wheelchair reference plane (rear view).

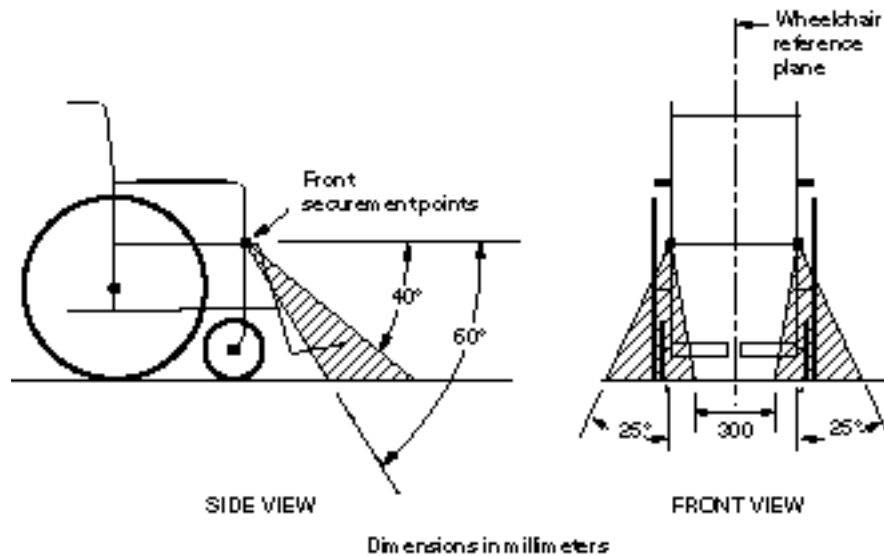

Figure 10 Preferred angles and locations of front tiedown straps from wheelchair securement points to vehicle anchor points. Front tiedowns should be angled out for lateral stability when possible.

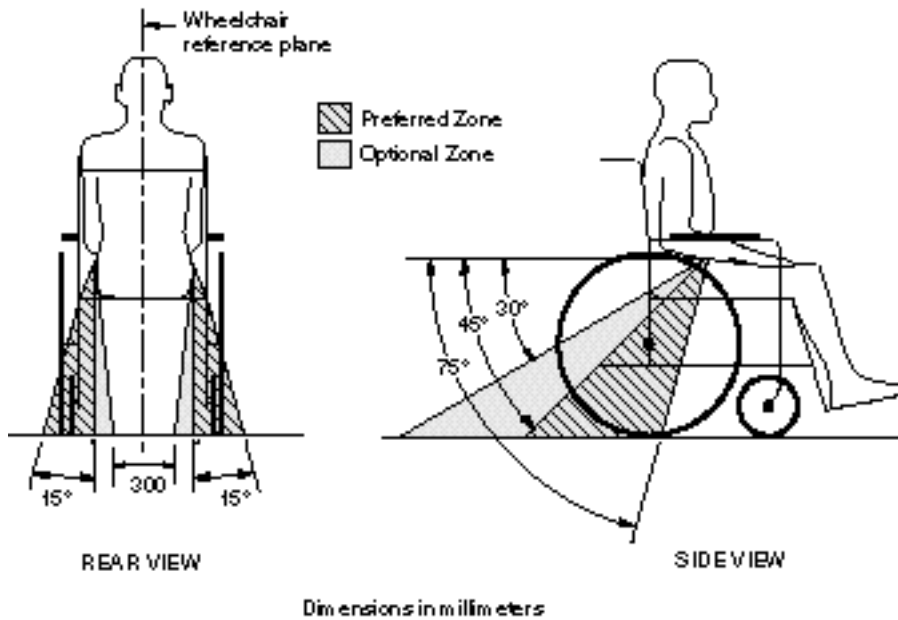

Figure 11 Preferred and optional angles for pelvic restraints.

- Recommended locations for upper anchor or upper guide support points of shoulder and harness restraints, and an explanation that these points should be positioned so that the belt webbing passes over the midpoint of the occupant’s shoulder and at a height that is at or above the level of occupant’s shoulders so as not to impose downward loads on the spine.
- Figure 12 and table 6 below provides guidance for the installation of shoulder belt anchorage points. Note the variation in dimensions depending upon occupant population.

Table 6
Typical values of SH, SB, W and seat height for Different Size Occupants

Occupant Size	Shoulder Height - SH (mm)	Half Shoulder Breadth - SB (mm)	Half Neck Breadth - W (mm)	Seat Height (mm)
6 year old	775	130	50	380
small female & 14-year-old	1000	175	75	450
midsize male	1100	200	75	500
large male	1200	210	75	550

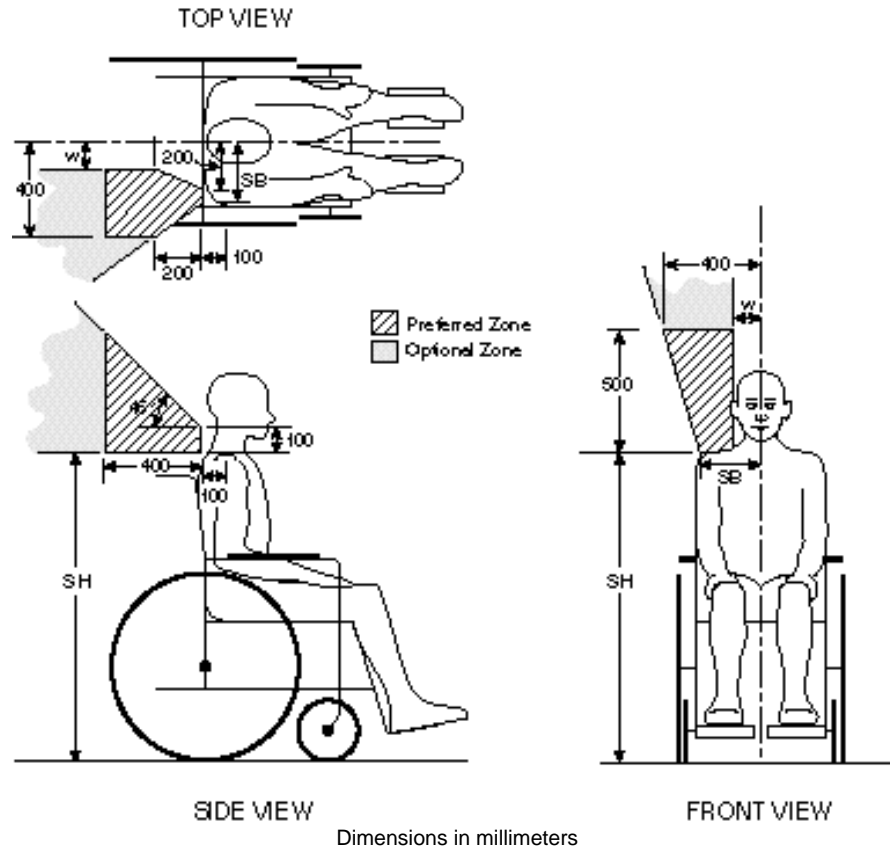

Figure 12-Preferred and optional zones for upper vehicle anchor point of shoulder restraint.

- _A forward and rearward clear zone should be provided so as to reduce potential for head impact with the vehicle interior in a crash. The clear zone should be approximately 16" behind the wheelchair seated occupant's head and roughly 37" in front of the occupant's head. This zone would be provided through the full height to the occupant's head, and should be the width of the securement station.
- _If a head restraint is anchored to the vehicle, a vehicle- anchored back restraint must be provided to minimize rearward deflection of the wheelchair seatback to prevent neck injury.
- _Provide energy absorbing and flame retardant padding (complying with FMVSS 302) to cover vehicle structures near the wheelchair securement station.
- _WTORS anchorages must be installed only into structurally suitable vehicle materials and adequately reinforced to assure WTORS crash integrity. The WTORS manufacturer should indicate anchorage strength requirements in their installation instruction.
- _Tiedown straps and occupant restraint belts should be stowed to avoid theft, vandalism or soiling. Webbing should be protected against contact with sharp edges.
- _Wheelchair seated drivers of vehicles equipped with airbags, should consult the National Highway Traffic Safety Administration for advice

regarding airbag disabling, since the airbag may cause injury to those sitting too close.

- _In the case of any questions regarding the WTORS, consult WTORS manufacturer for guidance.

VII. Guidelines for WTORS Designers

The information contained within this section is intended to provide WTORS designers with guidance related to the design and performance of their product. WTORS manufacturers are encouraged to obtain the actual SAE J2249 document for a complete representation of WTORS design requirements and performance criteria. The following guidelines focus primarily on the impact loading which WTORS may encounter in a 20 g/30 mph frontal sled impact test.

Expected Tiedown Loads

Loads from the wheelchair and occupant in a crash are transmitted to the vehicle floor through the front and rear tiedowns. Rear tiedown loads are typically greater than front tiedown loads in a frontal crash. Front tiedown loads may actually peak during the rebound phase of a crash. Tiedown loads can be influenced by a number of factors including the following:

- Crash Severity
- Vehicle Mass
- WTORS Configuration - Integrated vs. Independent WTORS
- Occupant and Wheelchair Weight
- Wheelchair Securement Location
- Wheelchair Stiffness Characteristics

The information below contains tiedown loading data derived through sled testing and computer simulations. These sled tests and computer simulations are representative of the SAE J2249 20g/30mph sled impact test crash pulse (SAE J2249 Appendix A). This frontal crash pulse is representative for a paratransit type van. Larger vehicles would experience less severe crash pulses, while smaller vehicles could encounter a more severe frontal crash pulse. WTORS loading would proportionally increase or decrease consistent with the crash severity.

The SAE J2249 sled impact test utilizes a 187 lb surrogate wheelchair occupied by a 50th percentile male, 168 lb test dummy. The wheelchair and occupant weights used in this test are intended to serve as a benchmark, although in actuality wheelchair and occupant weights will vary. Figure 1 shows the influence of combined wheelchair and occupant weight on rear tiedown load as calculated through computer simulations. WTORS in this study utilized a wheelchair-mounted (integrated) lap belt. The shoulder belt was mounted to the vehicle in an independent configuration. Therefore only a portion of the occupant load is placed on the rear tiedowns in this series of simulations. Rear tiedown peak loads vary from approximately 3500 lb to 7000 when combined wheelchair and occupant weight is varied from 210 to 460 lb (see figure 13).

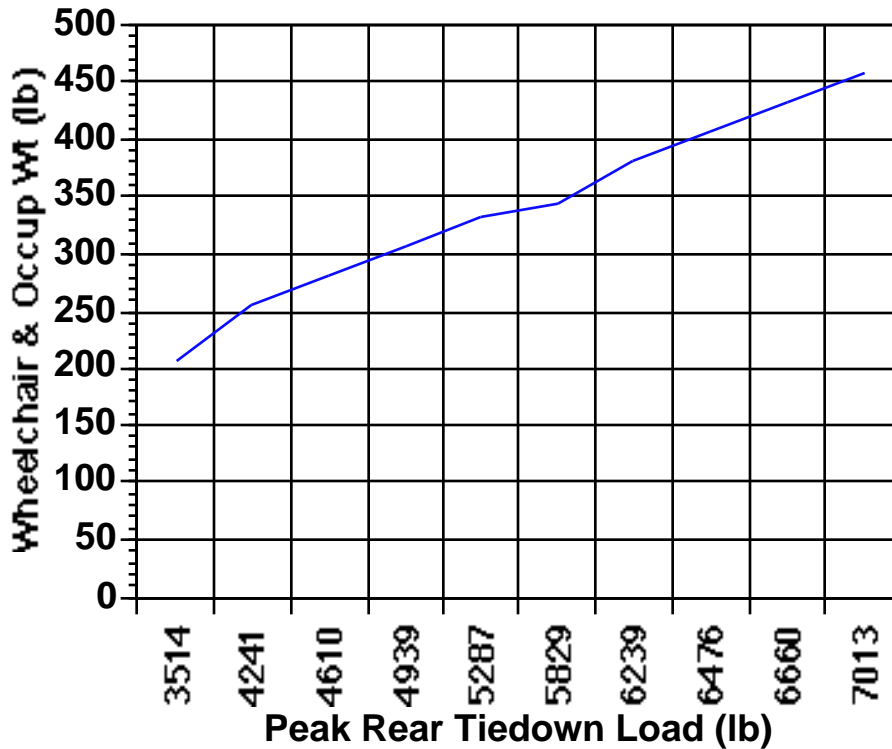

Figure 13 Rear Tiedown Loads for Varying Combined Wheelchair & Occupant Weight - 20g/30mph Frontal Crash

Note: Lap belt anchored to wheelchair, shoulder belt anchored to vehicle.

Table 7 provides loads measured through 20g/30 mph sled testing when using the 187 lb SAE J2249 surrogate wheelchair with a 168 lb 50th percentile male test dummy. Note that not all tests utilized the same WTORS configuration, i.e. integrated vs. independent restraints. As shown, rear tiedown loads vary significantly depending on whether the occupant load is transmitted through the rear tiedowns (integrated; SW 9608 & SW 9605) or directly to the floor (independent). Since the proposed ANSI/RESNA WC-19 WC Used as Motor Vehicle Seats Standard will require pelvic restraints to be anchored to the wheelchair, the combined loading of the occupant and the wheelchair will be applied to the rear tiedowns. Provisions will also be made through WC-19 to provide interface hardware on the pelvic belt which can act as the lower anchor point of the shoulder belt. Therefore, it is recommended that tiedowns be designed to withstand the combined wheelchair and occupant load.

Rear wheelchair securement point location can also influence front and rear tiedown loads. Table 7 provides tiedown forces measured through computer simulations as the rear securement point location was varied from above the wheelchair center of gravity to below the wheelchair center of gravity. As shown, tiedown loads can increase significantly when securement points are placed above the wheelchair center of gravity.

Table 7
Representative WTORS Loads for SAE J2249 20g/30mph Sled Tests

Test	WTORS Configuration	Peak Rear Tiedown Load (lb)
SW 9608	Integrated Restraint ¹	8463
SW 9605	Integrated Restraint ¹	8129
SW 9609	Independent Restraint	4810
SW 9606	Independent Restraint	4884

Note: All tests conducted using 187 lb SAE surrogate wheelchair and 168 lb ATD Lap belt & lower shoulder belt anchored to wheelchair

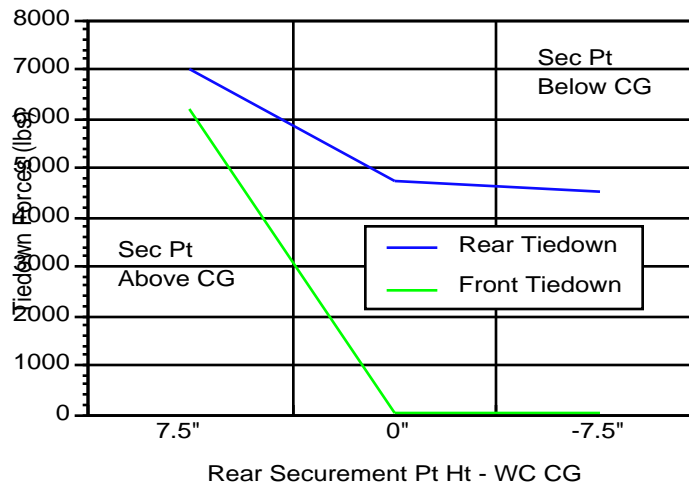

Figure 14 Rear Tiedown Load for Varying Securement Point Locations - 20g/30mph frontal crash

Predicted Occupant Restraint Loads

Occupant crash loads are transmitted to the vehicle floor either directly, or through the wheelchair or rear tiedown. Integrated restraints are anchored to the wheelchair or to the rear tiedown. Independent restraints are anchored directly to the vehicle floor. It is expected in the future that restraints will evolve to an integrated configuration since, as stated above, ANSI/RESNA WC-19 will phase-in (over two year) the requirement for wheelchair mounted lap belts which include shoulder belt interface hardware. This integrated approach will offer occupants with improved belt fit and hence, more effective occupant protection.

Some of the same factors which influence tiedown loads also affect occupant restraint loads. For example, increased crash severity will lead to increased occupant restraint loads. Therefore, for a given crash and occupant weight, occupant restraint loads are likely to be higher in a passenger car than in a large transit bus. Occupant weight largely

influences the loads placed on restraints. In a given crash, children will apply less load to restraints than an adult.

The SAE J2249 20g sled impact test utilizes the 50th percentile male, Hybrid III anthropomorphic test device (ATD) which weighs 168 lb as the benchmark occupant. Table 8 provides lap and shoulder restraint load data as measured during ten 20g/30mph frontal crash sled tests which utilized the 168 lb Hybrid III ATD.

Table 8
Representative Occupant Restraint Loads - 20g/30mph Frontal Crash

	Shoulder Belt Load	Lap Belt Load
# of Measured Values	10	8
Mean Load	2110 lb	2160 lb
Standard Deviation	290	470
Minimum Load	1810 lb	1560 lb
Maximum Load	2800 lb	2920 lb

As described through the sled test and computer simulation generated measures, tiedown and occupant restraint loads can fluctuate significantly depending upon conditions. That is, crash severity, vehicle size, wheelchair and occupant weight, restraint configuration, wheelchair stiffness, and securement point location can all influence the resulting loads placed upon WTORS. Load data provided above is intended only as guidelines for WTORS designers, as actual loads may vary. The SAE J2249 sled impact test used to evaluate WTORS crash performance is a benchmark that is important to assure a predicted level of performance for consumers selecting WTORS. Designers are encouraged to anticipate the evolving and future demands, such as trends in increased power wheelchair weight and totally integrated occupant restraints when designing their products.

VIII. Future additions to RP J2249

As can see in Appendix A, industry standards on wheelchair occupant protection are in various stages of completion. The work on any one set of standards is rarely ever complete. This is also the case with J2249. The present version, which is the core topic of this guideline is only just the being of what will hopefully be a series of standards that addresses many remaining unresolved wheelchair securement concerns. First, J2249, only addresses the issue of frontal impact. Although much less in frequency, impacts from other directions (side and rear) also occur under normal driving conditions. It is highly suspected that wheelchair-seated occupants will have less protection when impact forces are applied in those directions, because securement and restraint current systems have been optimized for frontal impacts. New tests procedures will be required in order to validate the crashworthiness of products when non-frontal crash loads are applied.

Although attempts have been made to make J2249 generalized to allow testing of docking systems, much less experience has been obtained with these devices and therefore revisions to J2249 may be required as more experience is gained with docking technologies.

The essence of J2249 is its standardized 30mph. 20g threshold crash test using a 85kg (187 lb) surrogate wheelchair occupied by a 76kg (167 lb) male ATD. It is known that there are power wheelchairs heavier than 187 lb being routinely used in the marketplace. However, the above crash loading approaches the limits of exiting four point strap technology. Over time, as the industry increases the strength of their tiedowns, the mass of the surrogate will likely need to be revised upward and thereby more closely representing the loads imposed by these heavier wheelchairs.

As indicated, J2249 uses a 30mph, 20g crash pulse. This is a world-wide motor vehicle industry standard that is more appropriate for small vehicles than it is for large vehicles. For example, it is statistically most unlikely that a wheelchair used in a large transit vehicles will ever see 20g loads, due to the large mass of the vehicle compared to others with which it may collide. Therefore, there is need for a new test and standard for those securement devices that are designed to only be used in large public vehicles.

Docking securement technology offers the real promise of providing securement independence for wheelchair users. However, one severe impediment to the development of docking devices is the wide range of wheelchairs in the marketplace. That is, there is no agreed upon standard way in which wheelchairs will connect to vehicle-anchored docking-type securement devices. Development of a universal interface hardware standard will go along way towards resolving this problem. Plans are currently underway to initiate this important activity.

IX. Appendices

Appendix A-Reference Standards, Laws and Regulations

1) Authorizing Federal Laws and Regulations

- FMVSS 222- School Bus Passenger Seating and Crash Protection, Federal Register, Vol.58, No. 10, January 15, 1993.
- ADA- Americans with Disabilities Act, 42 U.S.C. 12101, 1990

2) US National Voluntary Industry Standards

- SAE J2249- Wheelchair Tiedown and Occupant Restraints (Status 1/98-Ver.1-completed February, 1997)
- SAE J2252- Surrogate Wheelchair Drawing Package and Maintenance Manual (Status 1/98-under revision)
- ANSI/RESNA WC-19 Standards for wheelchairs used as Seats in Motor Vehicles (Status: target completion Spring, 1999)

3) Comparable Canadian National Standards

- CSA Z604 - Transportable Mobility Aids for Occupancy in Moving Vehicles (Status: completed February, 1997)
- CSA Z605 - Mobility Aid Securement and Occupant Restraint Systems for Motor Vehicles (Status: completed, February, 1997)
- CAN-D409-M84-Motor Vehicles for the Transportation of Physically Disabled Persons, ISSN 0317-5669, April 1994, Canadian Standards Association (Status: completed, October, 1992)

4) Comparable International Standards

- ISO 7176/19 Requirements and Test Methods for Transportation Wheelchairs for Use in Motor Vehicles (Status: target completion, Spring, 1999)
- ISO 10542-1&2 Wheelchair Tiedown and Occupant Restraint Systems for Use in Motor Vehicles (Status: completion, Spring, 1998)
- ISO 10542-3 Docking Systems (Status: target completion, Spring, 2000)
- ISO 10542-4 Clamping systems (Status: target completion, Spring, 2001)
- ISO 10542-5 Systems for Specific Wheelchairs (Status: target completion, Spring, 1999)

Appendix B-Glossary of Terms

Definitions of terms used throughout J2249:

Anchorage: An assembly of hardware and fittings by which loads are transferred directly from the wheelchair tiedown to the vehicle or from the occupant restraint to the vehicle, wheelchair, wheelchair tiedown, or vehicle seat base.

Anchor point: A point (area) on a vehicle, wheelchair, wheelchair tiedown, or vehicle seat base to which an anchorage is attached.

ANSI: Abbreviation for American National Standards Institute.

Anthropomorphic test device (ATD): An articulated analog of the human body used to simulate a motor-vehicle occupant in a crash environment.

Automatic-locking retractor: A retractor incorporating adjustment by means of a positive self-locking mechanism which is capable, when locked, of withstanding restraint forces (from J1834).

Back restraint: A device or system intended to limit rearward movement of the occupant by providing support to the back of the torso.

Belt: A length of energy-absorbing webbing material used as part of an occupant restraint.

Docking-type tiedown: A wheelchair securement device whose engagement is initiated as a result of the wheelchair rolling into the proper position.

Emergency-locking retractor: A retractor incorporating adjustment hardware by means of a locking mechanism that is activated by vehicle acceleration, webbing movement relative to the vehicle, or automatic action during an emergency, and that is capable, when locked, of withstanding restraint forces (from J1834).

End fitting: Anchorage and securement hardware to which tiedown and occupant restraint webbing is fastened and which attaches directly to the anchor points and securement points on the wheelchair, tiedown system, or vehicle.

Fasteners: Devices used to secure, by mechanical means, other components or parts in place.

Note: These include, but are not limited to, bolts, nuts, screws, pins, rivets, and clamps.

Forward facing: Orientation in which the wheelchair-seated occupant faces the front of the vehicle with the wheelchair reference plane within ten degrees of the longitudinal axis of the vehicle.

Four-point tiedown: A wheelchair tiedown system that attaches to the wheelchair frame at four separate points and anchors to the vehicle at four separate anchor points.

Note: The typical four-point tiedown system uses four tiedown straps with two attached to the front of the wheelchair and two attached to the back.

Harness: A restraint assembly consisting of at least one belt designed to provide pelvic restraint and two shoulder or torso belts that apply forces to both shoulders.

Head restraint: A device intended to limit rearward displacement of the occupant's head.

Impact simulator: A device for accelerating, decelerating, or a combination of decelerating and accelerating a section of a vehicle or simulated vehicle structures, including instrumentation for measuring pertinent data (from J850).

Impact sled: That part of an impact simulator on which components can be mounted for impact testing.

Independent occupant restraint: An occupant restraint that anchors directly to the vehicle or vehicle anchored components that are separate from the wheelchair and wheelchair tiedown.

Note: This is also known as a parallel restraint system.

Integrated occupant restraint: An occupant restraint for which the anchor points for the pelvic-restraint, or both pelvic- and shoulder-restraints, are located on the wheelchair, or on tiedown components not fastened to the vehicle.

Occupant restraint anchorage: An assembly of hardware and fittings by which loads are transferred directly from the occupant restraint to the vehicle, wheelchair, wheelchair tiedown, or vehicle seat base.

Occupant restraint: A system or device for restraining the occupant in a vehicle to prevent or minimize contact with the vehicle interior components and prevent ejection during a crash (from J2094).

OEM: Abbreviation for Original Equipment Manufacturer.

Pelvic restraint: That portion of a seat-belt assembly intended to limit movement of the pelvis.

Note: Other terms with similar meaning are lap belt, lap restraint, and lower torso restraint.

Point P: A reference point that lies at the cross-sectional center of a 100-mm-diameter cylinder positioned with the longitudinal axis perpendicular to the wheelchair reference plane such that the curved surface of the cylinder contacts with the backrest and the upper surface of the seat (see Figure 15).

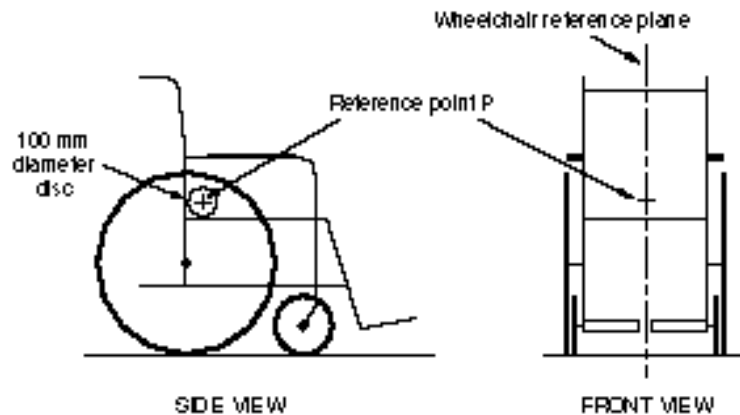

Figure 15 - Wheelchair reference point P and wheelchair reference plane.

Postural support: A component used to support a person in a desired position, but that is not usually intended to provide occupant restraint in a vehicle impact.

Securement hardware: End fittings of a wheelchair tiedown system that connect to the wheelchair.

Securement point: Location on the wheelchair frame to which a wheelchair tiedown end fitting connects.

Strap: A length of webbing material used as a part of a wheelchair tiedown.

Surrogate wheelchair: A rigid, reusable device used to simulate a wheelchair for the purpose of testing a WTORS.

SWC: Abbreviation for surrogate wheelchair.

Test wheelchair: A production, prototype, or surrogate wheelchair used to conduct tests specified in this recommended practice.

Three-point restraint: An occupant restraint assembly combining both a pelvic belt and diagonal shoulder belt that connect near the hip of the user (see Figure 16).

Two-point restraint: An occupant restraint assembly consisting of a single length of webbing and related components that anchors at two separate points (see Figure 17 for examples).

Upper torso restraint: A portion of a seat-belt assembly intended to restrain movement of the chest and shoulder regions (J140 and J141).

Wheelchair: A seating system comprised of a frame, a seat, and wheels that is designed to provide support and mobility for persons with physical disabilities.

Note: The term encompasses standard manual wheelchairs, powered wheelchairs, power-based wheelchairs, three-wheel scooter-type wheelchairs, and specialized seating bases.

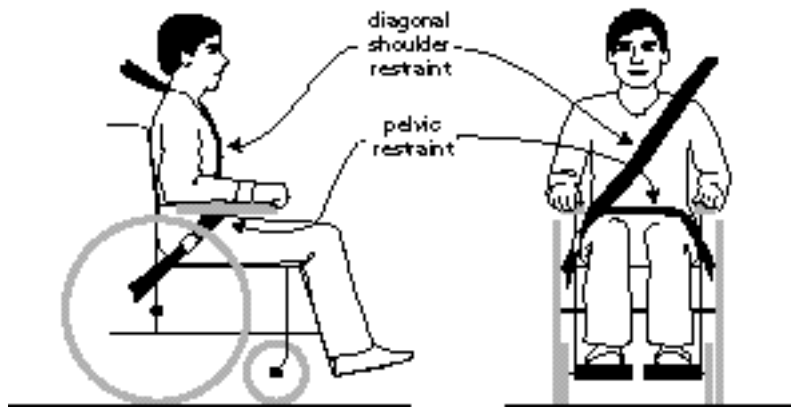

Figure 16 – Three-point occupant restraint. Wheelchair tiedown is also required but is not shown.

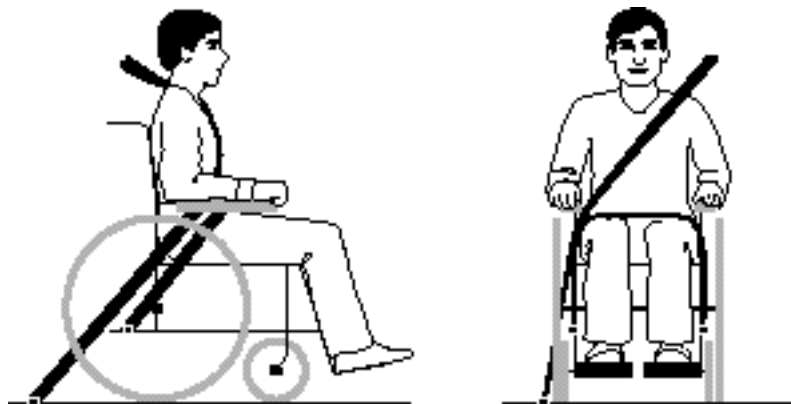

Figure 17 - Two-point vehicle-anchored shoulder restraint with two-point wheelchair-anchored pelvic restraint. Wheelchair tiedown is also required but is not shown.

Wheelchair reference plane: The vertical plane of symmetry in the longitudinal centerline of the wheelchair (see Figure 15).

Wheelchair tiedown and occupant restraint system (WTORS): A complete restraint system for wheelchair-seated occupants comprised of a system or device for wheelchair tiedown as well as a system for restraining the occupant.

Note: A complete WTORS includes all anchorage hardware and anchorage fasteners, or specifications for anchorage fasteners, required for installing and using the system in a vehicle. Complete WTORS may be designed with the intention of using the vehicle OEM occupant restraint system.

Wheelchair tiedown: A device or system designed to secure a wheelchair in place in a motor vehicle.

Note: Synonymous terms include wheelchair hold-down, wheelchair lock-down, wheelchair restraint, and wheelchair securement.

Wheelchair tiedown anchorage: An assembly of hardware and fittings by which loads are transferred directly from the wheelchair tiedown to the vehicle.

Appendix C -List of Participant Organizations, Companies and Individuals:

1) Organizations

Paralyzed Veterans of America--Jeff D.
NHTSA--Charles Hott, Gayle Dalrymple
SAE-Adaptive Devices subCommittee (ADSC)-Phil Doolittle -Chair
SAE- ADC-Task Group on Wheelchair Securement-Douglas Hobson
-Chair
Transport Canada-Roy Nishizaki, Barbara Smith
University of Michigan (UMTRI)--Lawrence Schneider, Miriam Manary
University of Middlesex (UK)--Peter Roy, Edward Stait
University of Pittsburgh (RERC)--Douglas Hobson, Gina Bertocci,
Kennerly Digges and Jean Webb
University of Virginia--Greg Shaw, John Thacker
Veterans Administration--Lou Molino,

2) Companies

ANCRA International--Ralph Abato
Division Industries--Scott Boldoc
Everest and Jennings Inc--Robert Clarke
EZ Lock Inc--Bruce Constantin
Indiana Mills Inc. James Johnson
Invacare Inc--Gil Haury
Kinedyne Inc--Joe Takacs
New Haven Equipment--Ray Lee
Ortho Safe Systems--Winifred Kraft
Q' Straint--Jean-Marc Girardin
Tie Tech Inc--Jack McIntyre
GESAC--N. Rangarajan

3) Additional Individuals (incomplete)

SAE Task Group participants:

Tom Adams	Roger Koppa
Gina Bertocci	Ray Lee
Scott Bolduc	Make McDermott
Lou Molino	Steve McKay
Kennerly Diggs	Larry Schneider
Jeff Dolozal	Greg Shaw
Phil Doolittle	Lyle Stevens
Laurin Garland	Joe Takacs
Peter Grandolfo	John Thacker
Charles Fitzsimmons	Margaret Young
Douglas Hobson-(Chair)	Winifred Kraft
Charles Hott	Carmella Starno
Patricia Karg	Gary Sherman